

## MODEL 8101CPU1 INTERFACE CARD

The Model 8101CPU1 Audio Interface Card is a component of the IED 8000 Series™.

The 8101CPU1 provides the following functions:

- Audio circuit (similar to the 8044AIO card) inputs and outputs for routing the 8101CPU-x Digital Record and Playback channels to the 8000 motherboard.
- The +5 V power for the 8101CPU-x.
- Interfaces the 8101CPU-x Serial Communications ports 3 and 4 through the 8101 motherboard which eliminates cabling directly to the 8101CPU-x CPU. These serial ports can now be connected to the rear of the 8011 Mainframe.
- Provides 8011 Mainframe fan control.
- 8011 Mainframe temperature sensing for frame and power supplies.
- Status indication of the 8101CPU1 Microcontrollers, including operation, resets, and +5 V power.
- Test points for +5 V to 8101CPU-x and +5 V on 8101CPU1.
- 8101CPU Reset function.
- Allows for universal interface to the 8011 system for ease of upgrades and changes to the 8101CPU-x.

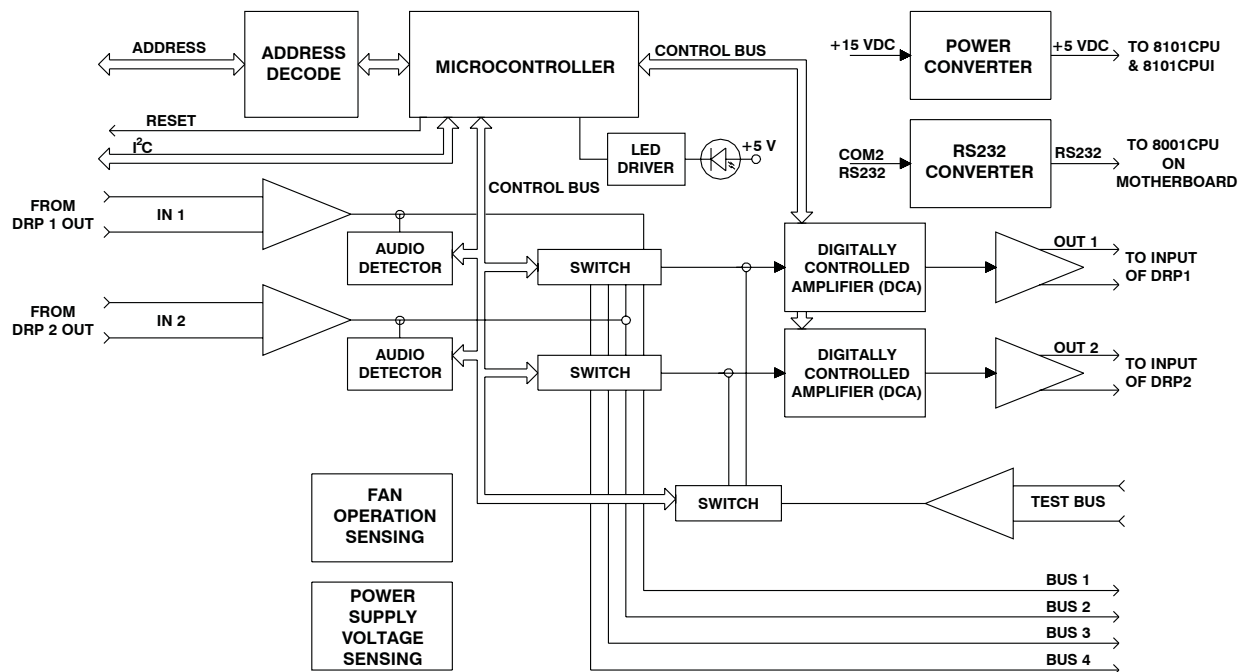

Figure 1 - 8101CPU1 Interface Card Block Diagram



A more detailed explanation of the features is as follows:

1. The audio circuit has two differential, electronically balanced inputs which can be switched to any of four buses which run the length of the mother board making it possible to source audio to/from other cards.

An Audio Test Signal Bus with a balanced input can be switched under software control to any output. The test tone will check the DCA, the output, and the MCU. This feature is used in conjunction with 8081MT cards and the 8011SA card to test audio points in the system with the 8000 Monitor/Test System. This feature also allows test tones to be introduced for testing functions on this card.

Also included is an audio detector circuit for each channel with speech-band filters and a level detector circuit. The audio detector is used to trigger events in the 8000 System (for example, to switch this input to a specified output), including an internal tone.

2. +5 VDC supply: it has a DC to DC converter which transforms the +15 VDC into +5 VDC for the 8101CPU-x.
3. Provide the path for communications ports 3 and 4 to be routed to the 8101 motherboard which allows them to be connected via ribbon cables to connectors on the rear panel of the 8011 Mainframe.
4. Provides the functions of optional control and monitoring of the fan operation. The fan turn-on speed is set by a resistor network on the 8011 motherboard to meet the operational airflow requirements. The speed is then modified by the control circuitry on the 8101CPUI, in accordance with the programmed parameters. There are a total of six fans in the 8011 Mainframe. Two are for cooling the 8012 Power Supplies (one for each supply). The other four are mounted on the front door, and provide cooling for the 8011 Mainframe. Each fan has its own powering and control circuit. Each of these circuits provides its own short circuit protection.

The on-board microcontrollers communicate with the 8001CPU and the 8011SA through an I<sup>2</sup>C bus on the mother board. A reset line from the mother board allows the MCU to be reset from the 8001CPU.

Various LED indicators, test points, and the reset switch are located on the front of the 8101CPUI. The LEDs are for the 8101CPU audio controlling MCU operating (green, leftmost LED), audio controlling MCU fault condition (red, center LED), fan controlling MCU operating (green, rightmost LED), fan controlling MCU fault condition (red, right of the audio MCU LED), and +5 V onboard 8101CPUI (green, rightmost LED).

Test points are located on either side of the LEDs. The test point for +5 V on the 8101CPUI is on the right, and the one for the +5 V on the 8101CPU is on the left. A red momentary push switch is provided to reset the 8101CPU.

*Innovative Electronic Designs, Inc. • 9701 Taylorsville Road • Louisville, Kentucky 40299 • USA  
Phone: (502) 267-7436 • Fax: (502) 267-9070 • Internet: <http://www.iedaudio.com>*

**SPECIFICATIONS**

**ELECTRICAL, ANALOG,  $V_S = +15\text{ V}$ ,  $-15\text{ V}$ , DCA gain set to  $+6\text{ dB}$**

1. Frequency Response . . . . .	+0, -0.1 dB
20 Hz - 20 kHz	
2. Total Harmonic Distortion, THD . . . . .	<0.01%
20 Hz - 20 kHz, 10 Hz - 80kHz filters	
3. Intermodulation Distortion, IMD . . . . .	<0.03%
60 Hz/7 kHz	
4. Signal-to-Noise Ratio, S/N . . . . .	> 90 dB
Referenced to +4 dBu, 20 - 22 kHz filters	
5. Crosstalk . . . . .	< -70 dB
Between any 2 audio paths, 20 Hz - 10 kHz	
6. DCA Control	
Range . . . . .	127 dB
Steps . . . . .	0.5 dB
Card Max. Gain . . . . .	25.5 dB
Card Max. Attenuation . . . . .	105.5 dB
7. Audio Detector Threshold . . . . .	-22.5 dBu
f = 4 kHz	
8. Maximum Input Level . . . . .	+24 dBu
9. Maximum Output Level . . . . .	+24 dBu
$R_L \geq 600\ \Omega$	
10. Power Supply	
Supply Voltage Range	
+15 V Supply . . . . .	+14.25 V to +15.75 V
-15 V Supply . . . . .	-14.25 V to -15.75 V
Supply current	
V= +15 V	
No audio input . . . . .	95 mA
Audio input = 18 dB, unity gain, $R_L = 600\ \Omega$ . . . . .	100 mA
V= -15 V	
No audio input . . . . .	70 mA
Audio input = 18 dB, unity gain, $R_L = 600\ \Omega$ . . . . .	77 mA

**INDICATORS**

1. MCU running . . . . .	Green LED
--------------------------	-----------

**CONNECTORS**

1. 64-pin . . . . .	EC64PR
---------------------	--------

**MECHANICAL**

1. Size (maximum overall dimensions as viewed from the front)	
Height . . . . .	(12.96 cm) 5.1"
Width . . . . .	(19.2 cm) 7.55"
Depth . . . . .	(3.18 cm) 1.25"

**ENVIRONMENTAL**

1. Operating Temperature Range . . . . .	(+32 °F - +122 °F) 0 °C - +50 °C
2. Storage Temperature Range . . . . .	(-40 °F - +158 °F) -40 °C - +70 °C



This page left blank intentionally

*Innovative Electronic Designs, Inc. • 9701 Taylorsville Road • Louisville, Kentucky 40299 • USA  
Phone: (502) 267-7436 • Fax: (502) 267-9070 • Internet: <http://www.iedaudio.com>*