

MODEL 8088VIO

8 INPUT/8 OUTPUT VARIABLE VOLTAGE CARD

The Model 8088VIO Variable Voltage Card is a component of the IED 8000 Series™. Through an 8-channel digital-to-analog converter it can provide 8 independent software controlled voltages. By using these voltages as references for external voltage controlled amplifiers, the gain of an audio system can be set and controlled.

A range switch can select 0 - 5 V in 19.6 mV steps or 0 - 10 V in 39.2 mV steps. Range selection is under software control, and the selected range applies to all output channels as a group, although each output can vary within the range individually.

Through an 8-channel analog-to-digital converter it can measure 8 external voltages. A range switch can select 0 - 5 V in 19.6 mV steps or 0 - 10 V in 39.2 mV steps. Range selection is under software control, and the selected range applies to all input channels as a group, although each input can read separate voltages within the range.

The same reference voltage which is used for the A/D converter is provided through a low impedance driver as an external reference for precise input measurements. By using the reference voltage as a source for the voltage across control pots, then using an inputs to measure the voltages at the wipers, more closely matched and predictable curves of input voltage versus pot rotation can be obtained.

Range selection, output voltage control, and input voltage determination are performed by an on-board microcontroller (MCU). The MCU communicates with the 8001CPU and 8001SA via an I²C bus. A reset line on the mother board allows the on-board microcontroller to be reset by the 8001CPU.

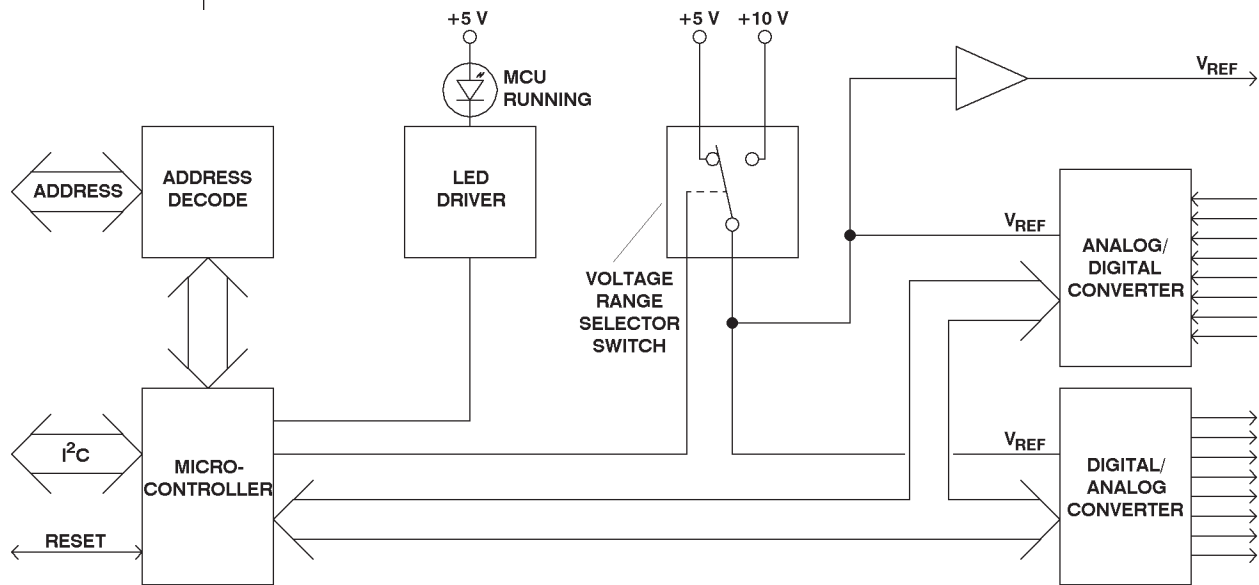

Figure 1 - 8088VIO 8 Input/8 Output Variable Voltage Card Block Diagram



SPECIFICATIONS

ELECTRICAL, ANALOG

1. Number of Voltage Inputs	8
2. Input Voltages	
Voltage Ranges (See note 1)	
High	0 - 10 V
Sensitivity	39.2 mV
Low	0 - 5 V
Sensitivity	19.6 mV
3. Number of Voltage Outputs	8
4. Output Voltages	
Voltage Ranges (See note 2)	
High	0 - 10 V
Steps	39.2 mV
Low	0 - 5 V
Steps	19.6 mV
Minimum Output Load Resistance, R_L , per output	2 k Ω
5. Power Supply	
Supply Voltage Range	
+15 V Supply	+14.25 V to +15.75 V
-15 V Supply	-14.25 V to -15.75 V
Supply current	
V= +15 V	52 mA
V= -15 V	28 mA
6. Number of Reference Voltage Outputs	2
7. Reference Voltage	
High	10 V
Low	5 V
Software selectable	
8. Reference Voltage Load Current, Max.	20 mA
Each output	

INDICATORS

1. MCU Running	Green LED
--------------------------	-----------

CONNECTORS

1. 32-pin Euro Connector, male, right-angle (2 each). . .	Hirose PCN10-32P-2.54DS
---	-------------------------

Note 1: Selected range applies to all 8 inputs.
 Note 2: Selected range applies to all 8 outputs.

Innovative Electronic Designs, Inc. • 9701 Taylorsville Road • Louisville, Kentucky 40299 • USA
Phone: (502) 267-7436 • Fax: (502) 267-9070 • Internet: <http://www.iedaudio.com>

MECHANICAL

1. Size (maximum overall dimensions as viewed from the front)
 - Height (11.43 cm) 4.50"
 - Width (2.03 cm) 0.80"
 - Depth. (20.42 cm) 8.04"
2. Weight (121 gm) 0.266 lb

ENVIRONMENTAL

1. Operating Temperature Range (+32 °F - +104 °F) 0 °C - +40 °C
2. Storage Temperature Range (-40 °F - +158 °F) -40 °C - +70 °C

PIN	FUNCTION	PIN	FUNCTION
1	Ch 7 Out	17	Ch 8 Out
2	Ground	18	Ground
3	Ch 5 Out	19	Ch 6 Out
4	Ground	20	Ground
5	Ch 3 Out	21	Ch 4 Out
6	Ground	22	Ground
7	Ch 1 Out	23	Ch 2 Out
8	No Connection	24	No Connection
9	No Connection	25	No Connection
10	Ch 7 In	26	Ch 8 In
11	V _{REF}	27	Ground
12	Ch 5 In	28	Ch 6 In
13	Ground	29	Ground
14	Ch 3 In	30	Ch 4 In
15	V _{REF}	31	Ground
16	Ch 1 In	32	Ch 2 In

Table 1 - Pin Connections, Upper Euro Connector



PIN	FUNCTION	PIN	FUNCTION
1	Address Line 4	17	Address Line 3
2	Address Line 2	18	Address Line 1
3	Address Line 0	19	I ² C Bus Interrupt Line (Inverted)
4	I ² C Serial Data	20	I ² C Serial Clock
5	+5 V	21	Master Reset Line
6	-15 V	22	-15 V
7	+15 V	23	+15 V
8	Spare 2	24	Spare 3
9	Ground	25	Ground
10	Ground	26	Ground
11	Ground	27	Ground
12	Audio Test Bus +	28	Audio Test Bus -
13	Audio Monitor Bus +	29	Audio Monitor Bus -
14	Audio Test Signal Bus +	30	Audio Test Signal Bus -
15	Internal Audio Routing Bus 2	31	Internal Audio Routing Bus 1
16	Internal Audio Routing Bus 3	32	Internal Audio Routing Bus 4

Table 2 - Pin Connections, Lower Euro Connector

Innovative Electronic Designs, Inc. • 9701 Taylorsville Road • Louisville, Kentucky 40299 • USA
Phone: (502) 267-7436 • Fax: (502) 267-9070 • Internet: <http://www.iedaudio.com>