

MODEL 8008RY
FORM C RELAY CARD

The Model 8008RY Form C Relay Card is a component of the IED 8000 Series™. It has 8 form C relays which are controlled by an on-board microcontroller (MCU).

The 800RY MCU communicates with the 8001CPU through an I²C bus on the mother board. A reset line from the mother board allows the MCU to be reset from the 8001CPU.

There are 8 green LEDs, one for each relay, which illuminate when the corresponding relay is energized. The LEDs are located in a column on the front edge of the card. The LED for relay #1 is located at the top of the column, with relay numbers increasing downward. Below the 8 green 'Relay Energized' LEDs is a green LED which lights when the MCU is running.

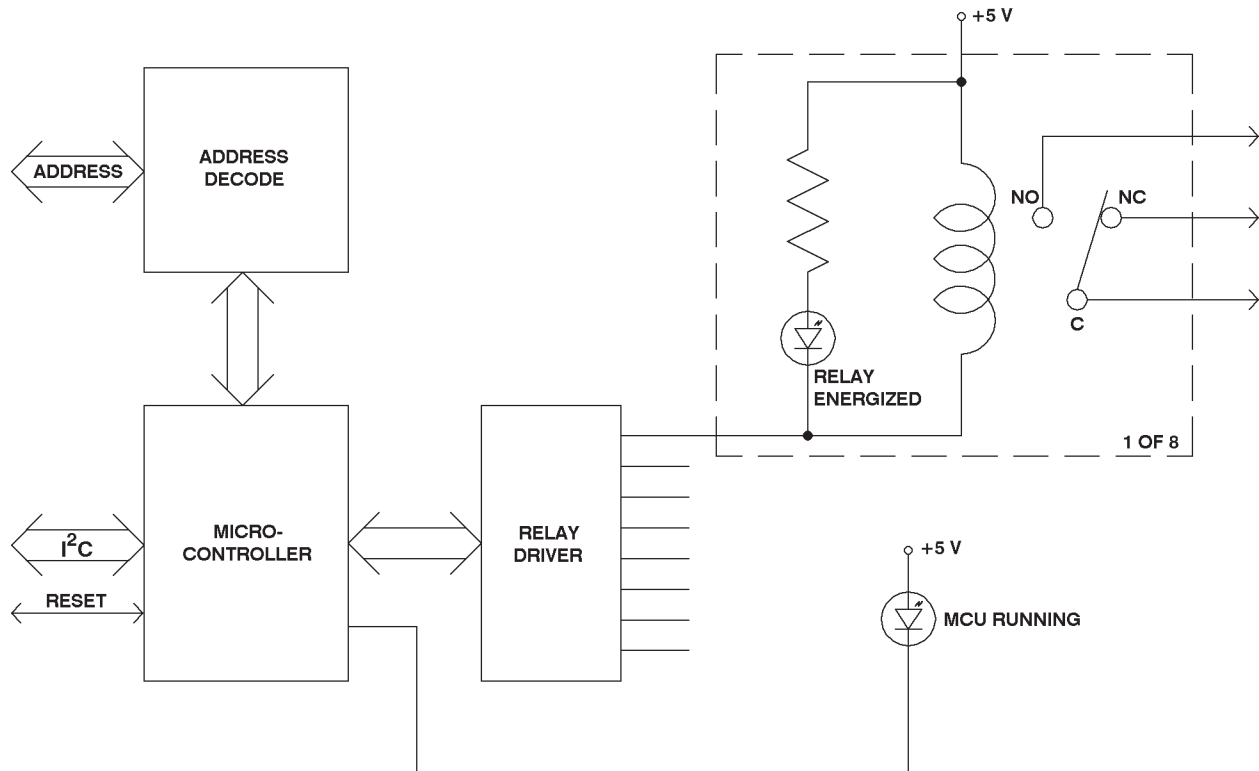

Figure 1 - 8008RY Form C Relay Card Block Diagram



SPECIFICATIONS

ELECTRICAL, ANALOG, $V_S = +15\text{ V}, -15\text{ V}$

1. Relay Contacts	
Load Supply Voltage = 120 VAC	0.5 A
Load Supply Voltage = 24 VDC	1.0 A
Load Supply Voltage = 60 VDC	0.3 A
2. Power Supply	
Supply Voltage Range	
+15 V Supply	+14.25 V to +15.75 V
-15 V Supply	-14.25 V to -15.75 V
Supply current	
All relays unenergized	
V= +15 V	22 mA
V= -15 V	0
All relays energized	
V= +15 V	85 mA
V= -15 V	0

INDICATORS

1. MCU running	Green LED
2. Relay Energized	Green LED
One LED per channel, numbered from top to bottom	

CONNECTORS

1. 32-pin Euro Connector, male, right-angle (2 each) . . .	Hirose PCN10-32P-2.54DS
--	-------------------------

MECHANICAL

1. Size (maximum overall dimensions as viewed from the front)	
Height	(11.43 cm) 4.50"
Width	(2.03 cm) 0.80"
Depth	(20.42 cm) 8.04"
2. Weight	(141 gm) 0.31 lb

ENVIRONMENTAL

1. Operating Temperature Range	(+32 °F - +104 °F) 0 °C - +40 °C
2. Storage Temperature Range	(-40 °F - +158 °F) -40 °C - +70 °C

Innovative Electronic Designs, Inc. • 9701 Taylorsville Road • Louisville, Kentucky 40299 • USA
Phone: (502) 267-7436 • Fax: (502) 267-9070 • Internet: <http://www.iedaudio.com>

PIN	FUNCTION	PIN	FUNCTION
1	RY 8 N.O.	17	RY 8 N.C.
2	RY 7 COMMON	18	RY 8 COMMON
3	RY 7 N.O.	19	RY 7 N.C.
4	GROUND	20	GROUND
5	RY 6 N.O.	21	RY 6 N.C.
6	RY 5 COMMON	22	RY 6 COMMON
7	RY 5 N.O.	23	RY 5 N.C.
8	GROUND	24	GROUND
9	GROUND	25	GROUND
10	RY 4 N.O.	26	RY 4 N.C.
11	RY 4 COMMON	27	RY 3 COMMON
12	RY 3 N.O.	28	RY 3 N.C.
13	GROUND	29	GROUND
14	RY 2 N.O.	30	RY 2 N.C.
15	RY 2 COMMON	31	RY 1 COMMON
16	RY 1 N.O.	32	RY 1 N.C.

Table 1 - Pin Connections, Upper Euro Connector

PIN	FUNCTION	PIN	FUNCTION
1	Address Line 4	17	Address Line 3
2	Address Line 2	18	Address Line 1
3	Address Line 0	19	I ² C Bus Interrupt Line (Inverted)
4	I ² C Serial Data	20	I ² C Serial Clock
5	+5 V	21	Master Reset Line
6	-15 V	22	-15 V
7	+15 V	23	+15 V
8	Spare 2	24	Spare 3
9	Ground	25	Ground
10	Ground	26	Ground
11	Ground	27	Ground
12	Audio Test Bus +	28	Audio Test Bus -
13	Audio Monitor Bus +	29	Audio Monitor Bus -
14	Audio Test Signal Bus +	30	Audio Test Signal Bus -
15	Internal Audio Routing Bus 2	31	Internal Audio Routing Bus 1
16	Internal Audio Routing Bus 3	32	Internal Audio Routing Bus 4

Table 2 - Pin Connections, Lower Euro Connector



This page left blank intentionally

*Innovative Electronic Designs, Inc. • 9701 Taylorsville Road • Louisville, Kentucky 40299 • USA
Phone: (502) 267-7436 • Fax: (502) 267-9070 • Internet: <http://www.iedaudio.com>*