

MODEL 8001CPU CENTRAL PROCESSING UNIT

The Model 8001CPU Central Processing Unit is a component of the IED 8000 Series™.

The card has an Inter-Integrated Circuit (I²C) serial bus interface. The I²C bus interface is used as the one of masters on the I²C bus which controls all cards which are components of the 8000 Series™ system. The 8001SA Signal Analysis Card also serves as a master on the I²C bus. The I²C bus is used by the 8001CPU to send commands to and to receive data from the other cards in the system. The bus is located on the mother board where it is available to all cards.

The 8001CPU card includes a multiple input A/D converter. One input of the A/D converter is connected to a temperature sensor whose purpose is to provide an indication of

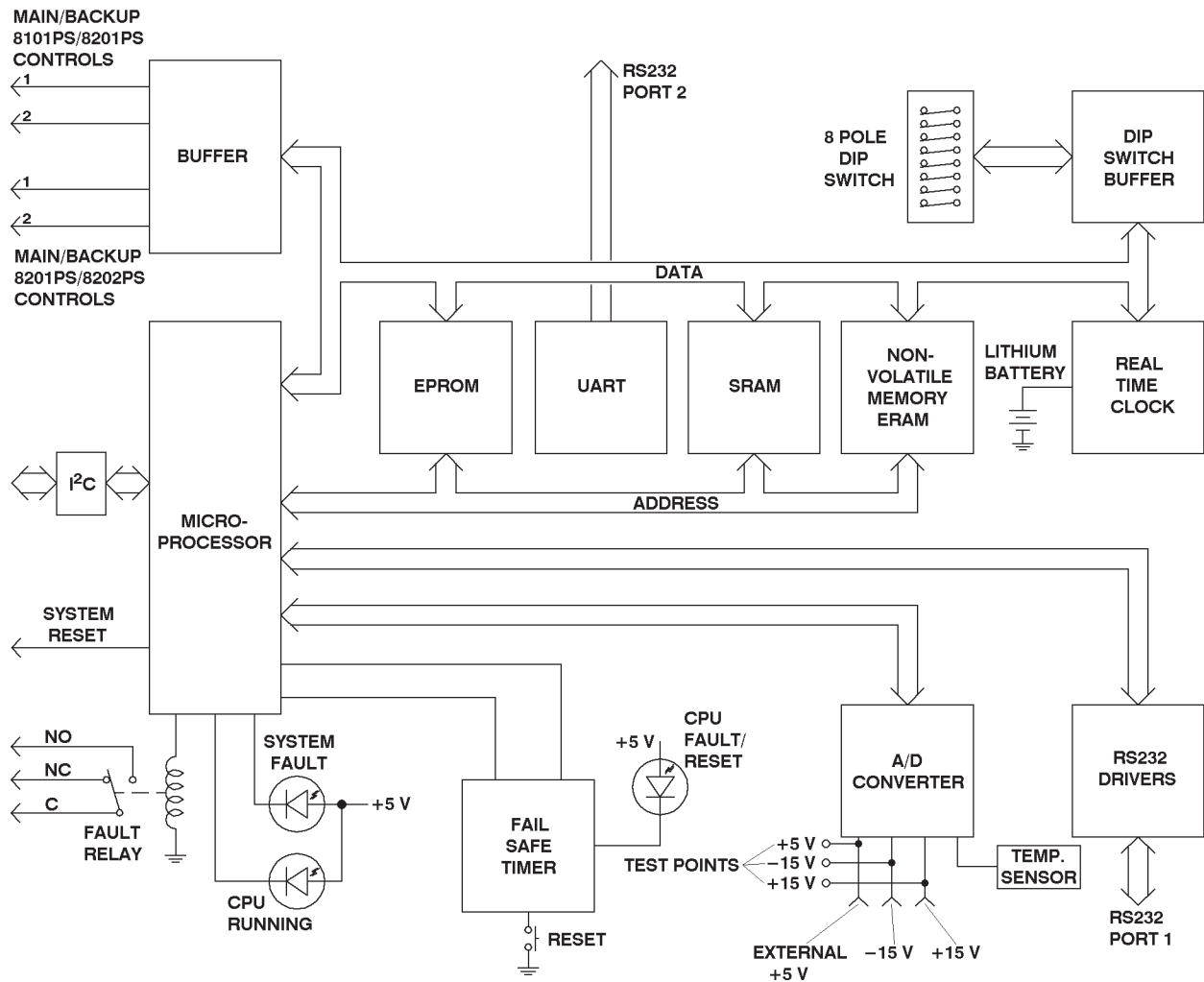

Figure 1 - 8001CPU Central Processing Unit

Block Diagram



the ambient temperature within the 8001MF Mainframe. The other three inputs to the A/D converter are used to monitor the +15 V, -15 V (8102PS, 8202PS), and +5 V external power supply outputs (8101PS, 8201PS) via suitably scaled connections.

Built into the microprocessor is a full duplex UART which is used as the onboard RS232 interface. Connection to the onboard RS232 interface is made through a 9-pin subminiature D connector located on the front edge of the card. Refer to Table 4 for pin connections.

There is also a second UART controlled by the main microprocessor which is used for the rear serial interface. This serial port can be configured for RS232 (8232RPTB), RS485 (8485RPTB), or RS422 (8422RPTB), depending upon which rear panel serial module is selected. The options are detailed in the 8001MF Product Description, Section 8, Group 01, Sub A.

The 8001CPU card outputs four bits which determine the mode (either Main or Backup) of each 8102PS/8202PS and 8101PS/8201PS Power Supply. If there is only one set of power supplies in the system, then the supplies are always kept in the Main mode. If there are two sets of power supplies, one set is kept in the Main mode and the other in Backup mode. If the monitored supply voltage of either type of supply goes outside the allowable limits, then that supply will be switched to backup mode.

One output of the microprocessor is connected to a timer (called the Fail-Safe Timer). If the microprocessor stops, the timer times out and provides a reset pulse to the microprocessor. A reset button located on the front edge of the card provides for manual reset of the microprocessor, if necessary. A red LED located on the front edge of the card remains lit while the microprocessor is being reset. This timer also resets the microprocessor if the voltage drops below a predetermined limit.

An 8-pole DIP switch, located near the front edge of the card, provides a number of system setup functions. Table 1 shows how combinations of positions of poles 1 and 2 produce the 4 baud rates obtainable for communication through the RS232 serial interfaces

Poles are numbered from right to left when facing the front of an 8000 Series™ mainframe.

Refer to Table 2 for settings of poles 3 - 8 of the DIP switch. Pole 3, when ON, tells the computer that a host computer is attached, enabling buffer up reports, host watchdogging, and requiring report acknowledging from the host.

The 8001CPU has a test mode which is used primarily at the factory for testing of individual cards. Pole 4 of the DIP switch determines whether or not the 8001CPU is in the test mode.

Poles 5 and 6 are for power supply presence setup. Pole 5, when ON indicates to the computer that two sets of 15 V power supplies are present. Pole 6, when ON indicates the presence of 5 V supplies (one or two, Main and Backup, depending upon Pole 5).

Pole 7 is used to enable the rear external serial port. When it is ON, that external serial port is enabled.

Included on the 8001CPU card is a form C relay which is used for fault indication. The relay is energized and held in the energized state by an output of the CPU, as long as no fault is detected. If a fault occurs, the relay is deenergized. The relay contacts are available on a plug-in screw terminal connector on the 8232RPTB, 8485RPTB, or the

*Innovative Electronic Designs, Inc. • 9701 Taylorsville Road • Louisville, Kentucky 40299 • USA
Phone: (502) 267-7436 • Fax: (502) 267-9070 • Internet: <http://www.iedaudio.com>*

8422RPTB when these panel options are ordered. Without one of these rear terminal options, the fault relay contacts are not available outside the mainframe.

A red LED on the front edge of the card serves as a fault indicator. It is driven by another output of the CPU. See Table 3 for system fault indications.

A buffered reset line driven by a separate output of the CPU is bussed to all usable card slots in the mainframe, so that all cards can be reset by the CPU, if needed.

A green LED on the front edge of the card serves as a CPU Running indicator. See table 3 for LED flashing information.

A real-time clock circuit provides real time information to the microprocessor. The clock circuit power supply is backed up by a long life lithium battery.

POLE 1	POLE 2	BAUD RATE
OFF	OFF	1,200
ON	OFF	2,400
OFF	ON	9,600
ON	ON	19,200

Table 1 - DIP Switch Poles 1 and 2
Baud Rates vs. Switch Settings

POLE	STATE	CONDITION
3	ON	Host computer is attached (e.g., buffer up reports, enable host watchdogging, require report acknowledgment from host)
	OFF	Host computer not attached
4	ON	Enter test mode (e.g., print DIP switches on reset, dump status periodically, ignore setup data in non-volatile memory)
	OFF	Do not enter Test Mode.
5	ON	Backup power supplies present (e.g., two +15 V supplies and two +5 V supplies. (Pole 6 indicates whether +5 V supply is present)
	OFF	Backup power supplies not present
6	ON	+5 V Power Supply present
	OFF	+5 V Power Supply not present
7	ON	Use external serial port for commands/reports in addition to the internal port
	OFF	Do not use external serial port for commands/reports in addition to the internal port
8	ON	Reserved for future use
	OFF	

Table 2 - DIP Switch settings
Poles 3 through 8



PIN	FUNCTION	PIN	FUNCTION
1	No Connection	6	DSR
2	RxD	7	RTS
3	TxD	8	CTS
4	DTR	9	No Connection
5	Ground		

Table 4 - DB9 Connector Pin Connections

SYSTEM FAULT (LEFT RED)	REBOOT/WATCHDOG (RIGHT RED)	ACCESS (GREEN)
SOLID ON - Indication of either critical or non-critical fault, depending on flag in ALRM entity (default is both kinds).	Normally ON only during 8000 power-up or when the reset switch is pressed. If ON at other times, indicates a problem with the 8001CPU (i.e., cannot run properly and watchdog timer is causing a reboot).	NORMAL - ½ second ON, ½ second OFF (unevenness can be caused by a long duration task such as formatting or transmitting data via RS232) EXCEPTION - During initialization it will remain in one state for over 1 second.
SINGLE FLASH - Power supply problem (one or more supplies not within spec. (RUN LED will not be lit on failed Power Supply).		
DOUBLE FLASH - Temperature Problem (above threshold, default = 50 °C, but can be set by user via diagnostics port).		
TRIPLE FLASH - A card has failed (not responding to I ² C commands).		

Table 3 - Status Lights

Innovative Electronic Designs, Inc. • 9701 Taylorsville Road • Louisville, Kentucky 40299 • USA
Phone: (502) 267-7436 • Fax: (502) 267-9070 • Internet: <http://www.iedaudio.com>

SPECIFICATIONS

ELECTRICAL, ANALOG

1. Power Supply
 - Supply Voltage Range
 - +15 V Supply +14.25 V to +15.75 V
 - 15 V Supply -14.25 V to -15.75 V
 - Supply current
 - V= +15 V 93 mA
 - V= -15 V 0 mA

INDICATORS

1. CPU Running Green LED
2. CPU Fault/Reset Red LED
3. System Fault Red LED

CONNECTORS

1. 64-pin Euro Connector, male, right-angle Hirose PCN10-64P-2.54DS
2. 9-pin sub-D, female.
See Tables 4 and 5 on pages 4 and 6 for pin connections.

MECHANICAL

1. Size (maximum overall dimensions as viewed from the front)
 - Height (11.43 cm) 4.50"
 - Width (2.03 cm) 0.80"
 - Depth. (20.42 cm) 8.04"
2. Weight (187 gm) 0.412 lb

ENVIRONMENTAL

1. Operating Temperature Range (+32 °F - +104 °F) 0 °C - +40 °C
2. Storage Temperature Range (-40 °F - +158 °F) -40 °C - +70 °C



PIN	FUNCTION	PIN	FUNCTION
1	Address Line 8	33	Address Line 9
2	Address Line 10	34	Address Line 11
3	Address Line 12	35	Address Line 13
4	Address Line 14	36	Address Line 15
5	Address Line 6	37	Address Line 7
6	Address Line 4	38	Address Line 5
7	Address Line 2	39	Address Line 3
8	Address Line 0	30	Address Line 1
9	No Connection	41	Data Line 6
10	Data Line 7	42	Data Line 4
11	Data Line 5	43	Data Line 2
12	Data Line 3	44	Data Line 1
13	Data Line 1	45	Write Enable (Inverted)
14	DSP Interrupt (Inverted)	46	Read Enable (Inverted)
15	-15 V	47	-15 V
16	+15 V	48	+15 V
17	Ground	49	Ground
18	Ground	50	Ground
19	Spare	51	Spare
20	Reset	52	I ² C Clock
21	I ² C Data	53	I ² C Interrupt (Inverted)
22	Transmit	54	Receive
23	Ground	55	No Connection
24	Ground	56	Ground
25	Ground	57	DSP Chip Select
26	+5 V	58	+5 V
27	Power Supply 1 Main/Backup Switch Bit	59	Power Supply 2 Main/Backup Switch Bit
28	No Connection	60	No Connection
29	Fault Relay Common	61	No Connection
30	Fault Relay Normally Closed	62	Fault Relay Normally Open
31	DSR	63	DTR
32	RxD	64	TxD

Table 5 - Pin Connections, Euro Connector

Innovative Electronic Designs, Inc. • 9701 Taylorsville Road • Louisville, Kentucky 40299 • USA
Phone: (502) 267-7436 • Fax: (502) 267-9070 • Internet: <http://www.iedaudio.com>