MODEL 6282L

DUAL 100 WATT, 8 OHM POWER AMPLIFIER CARD

The 6282L is a microprocessor controlled high performance, Class D (switching mode), dual 100 watt amplifier into 8 ohms (28.28 Volts into 8 ohms) for operation from a 120 VAC power source. It can be bridged into a single channel amplifier that can deliver 200 watts into an 8 ohm load (40 Volts into 8 ohms). The 6052L CPU card communicates with all 8 dual channel amplifiers in a single rack over an I²C bus located on the mother board. The 6052L interrogates the amplifiers in the system for information and sends certain commands to the on-board amplifier processor.

Class D operation combined with an integral switching mode power supply offers many advantages, and the unique IED design makes full use of these benefits. They include higher efficiency, increased reliability, improved performance, and lower cost. Switching mode operation combined with high voltage power MOSFET devices make it possible to eliminate the heavy, costly, bulky transformers. IED's design is stable under all load conditions (phase angles of 0 to 360 degrees).

The 6282L utilizes a dual channel digital volume control to adjust the input gain of the amplifier. The volume control has an adjustable range of 127 dB in 0.5 dB steps which is achieved through 95.5 dB of attenuation and 31.5 dB of gain. The input volume control is nominally set to 17 dB of gain to reach full output in the mono mode of 200 Watts with an input signal level of 900 mV. For embedded applications (applications without the 6052L), the on-board processor reads two 6 pole DIP switches, one DIP switch on the front of the amplifier for each channel, to adjust the input attenuation. The 6 pole DIP switch has been configured to have a range of 0-63 dB of attenuation in 1 dB steps for each channel. The attenuation is below the nominal gain setting of 17 dB. If the amplifier is configured in the mono mode then only the upper, channel 1 DIP switch will control the input gain of the amplifier.

The 6282L utilizes a voltage limiter which limits the audio in a lower level stage and reports to the on-board processor whether either one of the channels is into voltage limiting. The voltage limiting can be accomplished when the amplifier is in a dual channel mode or a single channel mode and this is configured by the on-board processor. For embedded applications the voltage limiting is set depending on the mono/dual jumper set on the mother board. The 6282L output voltage is limited to 28.28 V_{RMS} on each channel if configured for dual channel mode or is limited to 40 Volts in the single channel mode.

The on-board processor monitors the temperature at the heat sink between the output power FETs in °C. In embedded applications the on-board processor monitors the heatsink temperature and will make adjustments to the input gain depending on the temperature rise of the heatsink.

The 6282L utilizes audio output voltage feedback to the on-board processor for analysis of the output voltage on a real time basis. The output voltage from each channel is rectified, scaled and sent back to an A/D converter input on the on-board processor.

The 6282L utilizes a current to voltage converter on each output. The voltage of this ratio for each channel is rectified, scaled and sent back to an A/D converter input on the on-board processor. The on-board processor with the output current information can control individual audio output over-current conditions and reduce the input gain of either



channel to compensate for overloading of its output. Once the overload condition is corrected then the processor can reset the input gain back to its previous setting.

Addressing of the 6282L cards is done on the motherboard so that any card can be installed in any slot in the mainframe without changing any setting on the amplifier card itself.

The amplifier card has 5 LEDs located on its front edge. There is one green LED, two yellow LEDs and two red LEDs. The green LED when lit steadily, represents that the amplifier is powered up and that the processor is running properly. If it is flashing, then the power supply is functional but the on-board processor is not running. If it is off then the power supply and amplifier is not functional. The yellow LEDs represent output signal presence of the amplifiers. The signal presence LED turns on when 3 V RMS is detected on the amplifier output. The red LEDs represent either voltage limiting or current limiting on each channel. If the amplifier is configured in the mono mode then only the channel 1 LEDs will illuminate.

The 6282L when plugged into the mainframe will be initialized by a jumper in embedded applications to tell it that that slot in the mainframe is configured for a single channel mode or the dual channel mode. The on-board processor then will configure input analog switches and voltage limiting circuit for single channel or dual channel operation. For single-channel operation, the on-board processor reads only the top DIP switch to set input attenuation and drive only one set of LEDs on the front of the amplifier.

The 6282L provides +24V through current limiting resistors for operation of the fans in the rear of the mainframe. The amplifier and mainframe are setup so that an amplifier in slot 1 will operate fan #1; slot 3 will operate fan #2; slot 5 will operate fan #3; slot 7 will operate fan #4.

The AC line is fused for over current protection in the power supply stage. It also has a switch on board to turn each individual amplifier on and off without having to take the entire frame power down.

*Innovative Electronic Designs, Inc. • 9701 Taylorsville Road • Louisville, Kentucky 40299 • USA
Phone: (502) 267-7436 • Fax: (502) 267-9070 • Internet: <http://www.iedaudio.com>*

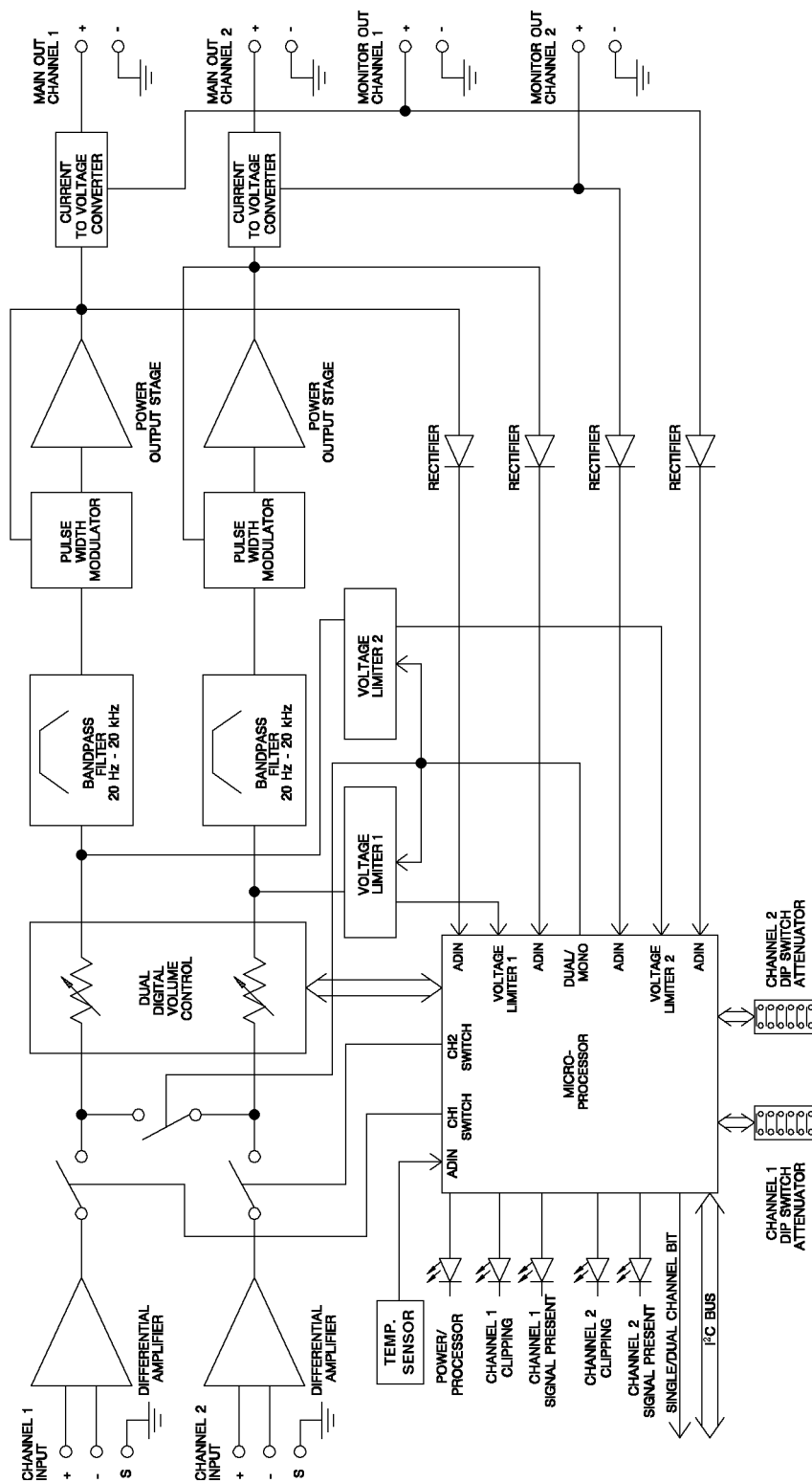

Figure 1 - 6282L Block Diagram



SPECIFICATIONS

ELECTRICAL, ANALOG

Dual Channel Mode, Each Channel	
1. Number of outputs	
Main	2
Current Monitor	2
2. Power Output, $R_L=8$	100 W (28.28 V)
3. Efficiency	
Power Output = 100 W	79%
Power Output = 50 W	76%
Power Output = 25 W	67%
4. Power Input (AC)	18 W
Power Output 1 W	
5. Voltage Clipping Level	40 V
Peak Voltage	
6. Overcurrent Trip Point	5.0 A
Peak Current	
7. Frequency Response	+0, -1 dB
20 Hz - 20 kHz	
8. Power Bandwidth	20 Hz - 20 kHz
-3 dB	
9. Signal-to-Noise Ratio	>85 dB
Unweighted, 20 Hz - 20 kHz	
10. Total Harmonic Distortion, THD	<0.5%
$P_O = 100$ W, 20 Hz - 10 kHz, 10 kHz - 30 kHz filters	
11. Input Sensitivity	636 mV
$P_O = 100$ W, $R_L = 8$	
12. Input Impedance	24 k
Balanced	
13. Input Common Mode Rejection Ratio, CMRR	>70 dB
20 Hz - 20 kHz	
14. Output Impedance	0.6
15. Output Loading	8
20 Hz - 20 kHz	
16. Damping Factor	>13
20 Hz - 20 kHz	
17. Power Supply	
Supply Voltage Range	100 - 130 VAC
Supply Current	1.05 A
$V_{LINE} = 120$ VAC	
18. Overcurrent Protection	3 A, 3AG Fuse

Innovative Electronic Designs, Inc. • 9701 Taylorsville Road • Louisville, Kentucky 40299 • USA
Phone: (502) 267-7436 • Fax: (502) 267-9070 • Internet: <http://www.iedaudio.com>

Mono Mode, Channels Paralleled

1. Number of outputs	
Main	1
Individual channel Main outputs paralleled	
Current Monitor	2
2. Power Output, $R_L=8$	200 W (40.0 V)
3. Efficiency	
Power Output = 200 W	79%
Power Output = 100 W	76%
Power Output = 50 W	67%
4. Power Input (AC)	18 W
Power Output 1 W	
5. Voltage Clipping Level	56 V
Peak Voltage	
6. Overcurrent Trip Point	7.0 A
Peak Current	
7. Frequency Response	+0, -1 dB
20 Hz - 20 kHz	
8. Power Bandwidth	20 Hz - 20 kHz
-3 dB	
9. Signal-to-Noise Ratio	>88 dB
Unweighted, 20 Hz - 20 kHz	
10. Total Harmonic Distortion, THD	<0.4%
$P_O = 200$ W, 20 Hz - 10 kHz, 10 kHz - 30 kHz filters	
11. Input Sensitivity	900 mV
$P_O = 200$ W, $R_L = 8$	
12. Input Impedance	24 k
Balanced	
13. Input Common Mode Rejection Ratio, CMRR	>70 dB
20 Hz - 20 kHz	
14. Output Impedance	0.3
15. Output Loading	8
20 Hz - 20 kHz	
16. Damping Factor	>26
20 Hz - 20 kHz	
17. Power Supply	
Supply Voltage Range	100 - 130 VAC
Supply Current	2.11 A
$V_{LINE} = 120$ VAC	
18. Overcurrent Protection	3 A, 3AG Fuse



CONTROLS

- 1. Input Attenuator DIP Switch (2, one per channel). 1 dB steps, 0 - 63 dB Accuracy
 - 0 - 31 dB 0.2 dB
 - 32 - 63 dB 0.4 dB
- 2. Power Switch Two position slide switch

INDICATORS

- 1. Clipping Level Red LED
 - 2, one per channel
- 2. Signal Present Yellow LED
 - 2, one per channel
- 3. Power 'On' and CPU Running Green LED
 - LED lit continuously Power On and CPU Running
 - LED flashing Power On, CPU being Reset
 - LED off Power Off

PIN	FUNCTION	PIN	FUNCTION
1	AC Line High	2	AC Line High
3	AC Line Neutral	4	AC Line Neutral
5	No Connection	6	No Connection
7	Dual/Mono	8	Address 2
9	Address 1	10	Address 0
11	Ch 2 Monitor -	12	Ch 2 Monitor +
13	Ch 1 Monitor -	14	Ch 1 Monitor +
15	Ch 2 Output +	16	Ch 2 Output +
17	Ch 2 Output Common	18	Ch 2 Output Common
19	Ch 1 Output +	20	Ch 1 Output +
21	Ch 1 Output Common	22	Ch 1 Output Common
23	Fan -24 V	24	Fan +24 V
25	I ² C Serial Clock	26	I ² C Serial Data
27	Ground	28	Ground
29	Ch 2 Input +	30	Ch 1 Input +
31	Ch 2 Input -	32	Ch 1 Input -

Table 1 - Pin Connections

*Innovative Electronic Designs, Inc. • 9701 Taylorsville Road • Louisville, Kentucky 40299 • USA
 Phone: (502) 267-7436 • Fax: (502) 267-9070 • Internet: <http://www.iedaudio.com>*

CONNECTORS

- 1. 32-pin Euro Connector Panduit 100-032-033
 For pin connections, see Table 1

MECHANICAL

- 1. Size (maximum overall dimensions)
 - Height (16.4 cm) 6.45"
 - Width (5.03 cm) 1.98"
 - Depth (32.0 cm) 12.6"
- 2. Weight (1402 gm) 3.09 lb

ENVIRONMENTAL

- 1. Operating Temperature Range. (32 °F - 122 °F) 0 °C - +50 °C
- 2. Storage Temperature Range (-40 °F - 158 °F) -40 °C - +70 °C



This page left blank intentionally

*Innovative Electronic Designs, Inc. • 9701 Taylorsville Road • Louisville, Kentucky 40299 • USA
Phone: (502) 267-7436 • Fax: (502) 267-9070 • Internet: <http://www.iedaudio.com>*