

MODEL 540M

AMBIENT ANALYSIS SYSTEM MAINFRAME

The IED Model 540 Ambient Analysis System is a subsystem of the 500 Series Audio Control System. The Model 540 controls sound system channel levels in response to ambient or background noise levels.

The Model 540M Mainframe houses and interconnects the 540PS Power Supply, the 540CPU Central Processor Card, and the 540I/540IAC Attenuator Card(s) which make up the system. Compression-type screw terminal connectors for the audio inputs, audio outputs, and the Model 540S Remote Sensors are located on the rear of the 540M.

Figure 1 shows a portion of the rear panel of the 540M Mainframe which includes the AC power connector, the RS422 connection from the computer (RS422 Input), the RS422 connection to the next 540M (RS422 Output), and the compression-type screw terminal connectors for card slot 1 which include the 4 audio channel inputs and outputs and the 4 remote sensor connections. Card slots 2 - 11 are similar.

All audio and sensor connections are made using individual standard audio shielded twisted pair cables such as Belden 8451, or equivalent. In multi-mainframe systems, the mainframes are linked via the RS422 ports. The RS422 ports actually conform to the PA422 Standard, and the term RS422 is used for simplicity.

Note: 540S Ambient Noise Sensors may not be daisy chained or wired in parallel. Each 540S requires its own shielded twisted pair connecting it to the 540M Mainframe.

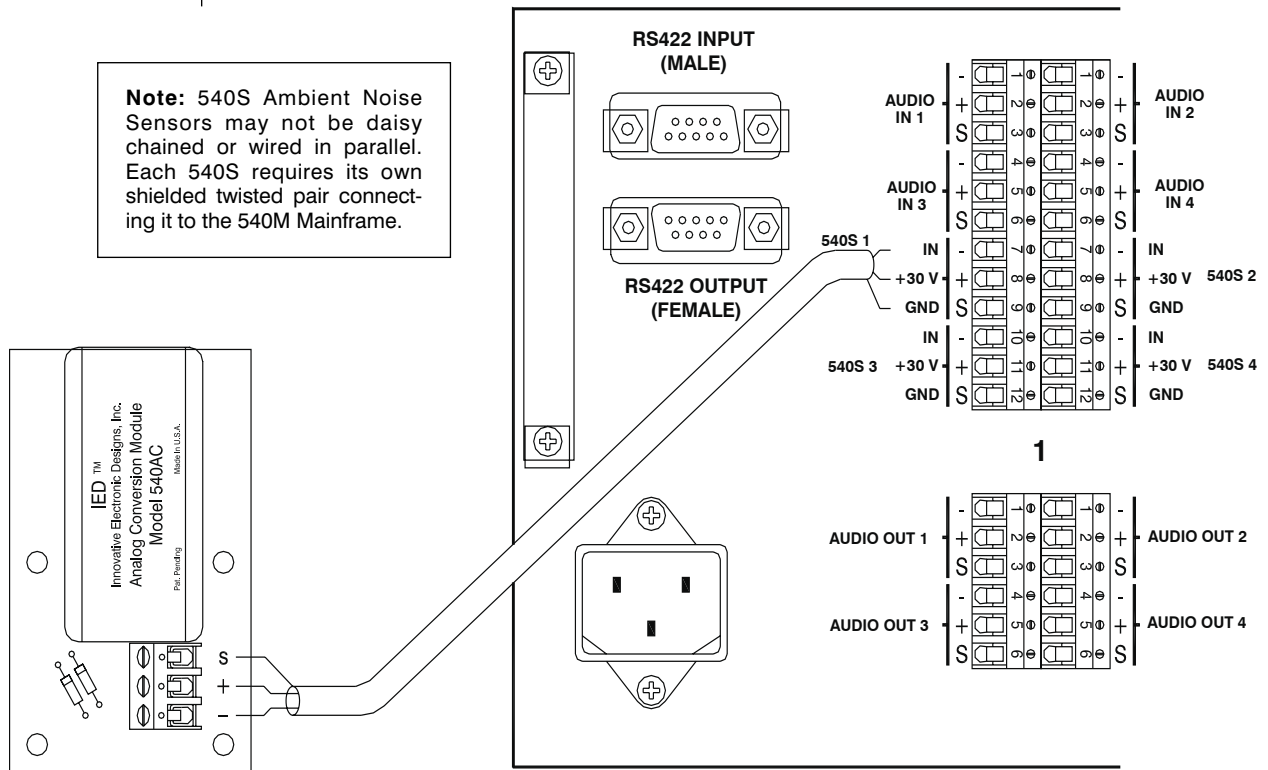

Figure 1 - 540 Rear Panel Terminal Connections
With RS422 serial port communication with 590 Computer



The IED 422LAN card is used only with the Windows version software. When the LAN card is used it is necessary to install an EPROM programmed for this software. Use only version 2.4, dated 7/15/02, or later. A typical EPROM label appears below. If the first line of the label ends with an "A" followed by a number as below, the IP address of the 422LAN card is fixed. If not present, the address is variable. Fixed addresses are burned into the EPROM. Variable addresses are set by the software. Refer to IED Data Manual, Section 9 Group 35 Sub C for address setup instructions. The 540I/540IAC Cards also have hardware addresses set by the software.

540CNC.BIN A5
 VERSION: 2.4
 IED0540CPU
 07/15/02

Note: Power down the system before installing or removing any function cards or installing or removing any wiring!

When wiring is complete, install the 540PS Power Supply Card. Power up the system. The 3 LEDs on the front edge of the power supply card should all be lit. They indicate, from top to bottom, +15 VDC, -15 VDC, and +30 VDC. Check these voltages using a

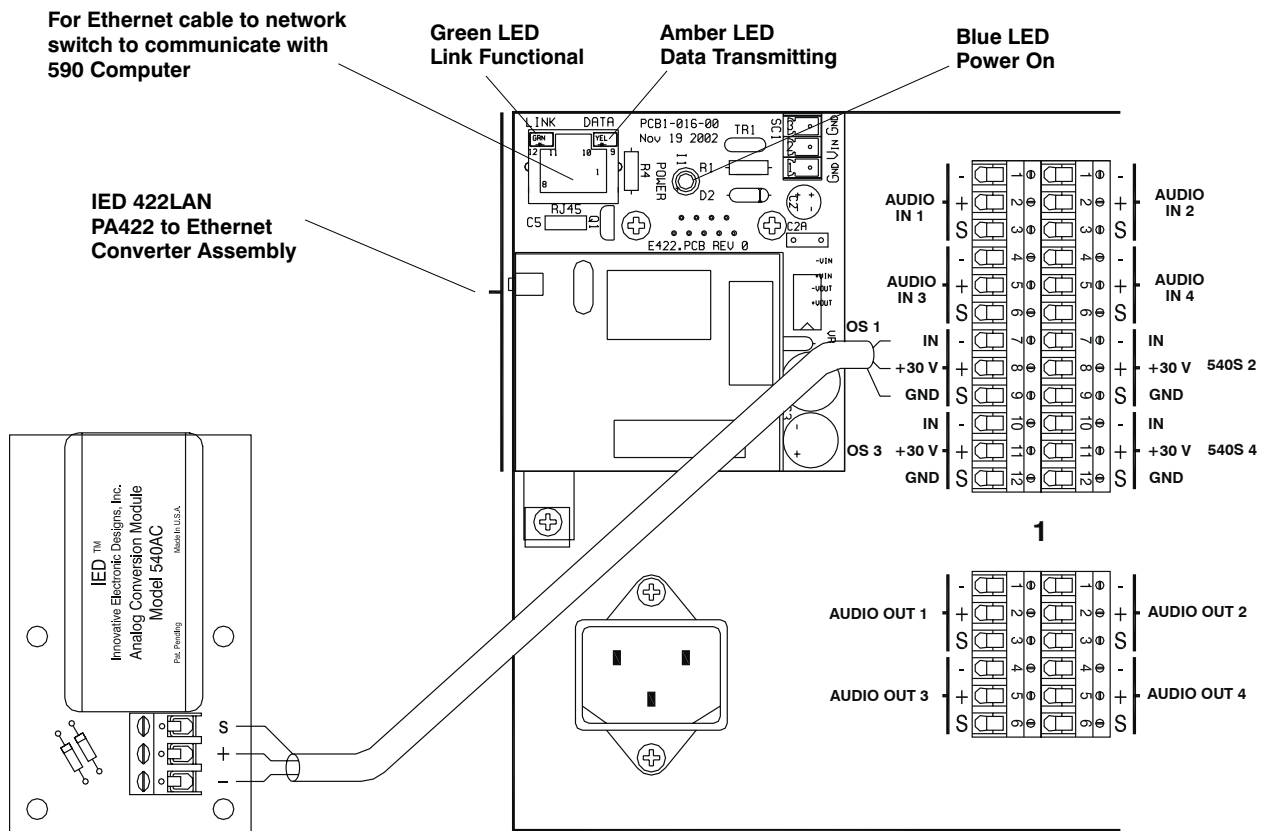

Figure 2 - 540 Rear Panel Terminal Connections
 With 422LAN added for communication with 590 Computer

*Innovative Electronic Designs, Inc. • 9701 Taylorsville Road • Louisville, Kentucky 40299 • USA
 Phone: (502) 267-7436 • Fax: (502) 267-9070 • Internet: <http://www.iedaudio.com>*

voltmeter. Test points for each and a ground test point are located on the front edge of the card near the bottom. If the voltages are correct, power down the system and install the 540CPU Card and 540IAC cards.

Power up the system and observe the LED indicators which are located on the 540CPU card. From top to bottom these LEDs indicate Fault, Run, and Flash Busy. The Fault LED might light momentarily during startup, but should turn off. The Run LED should remain lit. The Flash Busy LED is used to assist in identifying the currently selected mainframe which is used by the software. For more details, refer to the Model 635 Ambient Analysis System Software, Windows version Operating Instructions, Section 9 Group 35 Sub C.

The 540IAC Cards each have an LED which indicates the presence of +30 VDC. If this LED does not light it could mean that a remote sensor is wired incorrectly. **If this should occur, power the system down immediately and check the remote sensor wiring.** If allowed to remain powered up with the LED not lit for a long period of time damaged to the card might occur, or the power supply fuse might blow. After correcting any remote sensor wiring errors power the system up again. If the LED still does not light, power down again and check for card damage or a blown fuse.

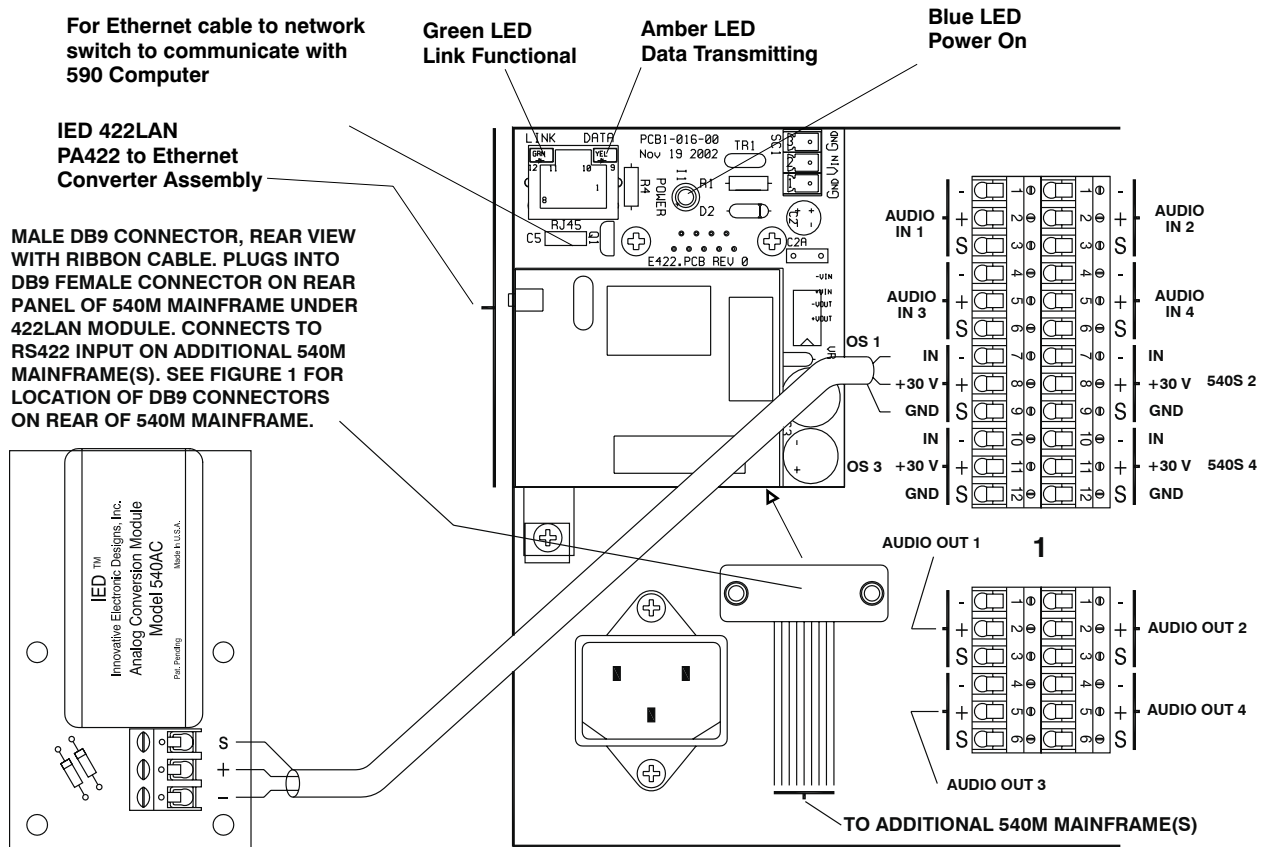

Figure 3 - 540 Rear Panel Terminal Connections 422LAN and RS422 connection For communication with additional 540M Mainframe(s)



