

## 5401NQ, 5401NQ-8, 5401NE

### 4 INPUT, 1 OUTPUT NULL AND EQ CARDS

The 5401NQ is a subgroup of the 5000 Series Audio Processing System. It is specifically designed to perform the nulling and EQ functions in a mix minus system. The 5401NQ subgroup consists of three cards as described in Table 1.

All of the 5401NQ subgroup cards have electronically balanced inputs with provisions on board for grounding the “-” input when connecting to an unbalanced source, eliminating the need for jumper wires on the mainframe.

MODEL	NUMBER OF INPUTS	INPUT LEVEL	NUMBER OF OUTPUTS	OUTPUT LEVEL
5401NQ	4	Line	1	Line
5401NQ-8	4	Line	1	Speaker
5400NE	4	Line	0	-

Table 1 - 5401NQ Family  
Model Numbers and Configurations

The 5401NQ has a balanced, floating output. The 5401NQ-8 has a Model 208S power amplifier in the output which is capable of driving 8 Watts into an 8  $\Omega$  load. The 5400NE is similar to the 5401NQ except that it is for input expansion only. It has no normal output.

Following the input stage, there is a stage whose gain can be adjusted to set up the appropriate nulls for mix minus operation. Gain is set with an eight position DIP switch. Each input has its own DIP switch. There is one DIP switch setting for creating a complete null with reference to the auxiliary output of the automatic mixer. This setting produces a complete null without any pot adjustment. This position will guarantee at least 45dB null from the reference input.

Six of the other DIP switch positions on each channel allow for setting up the nulls for each channel with respect to the reference input. There are 16 different nulls that can be accomplished with the settings of the 6 remaining DIP switch positions. The actual nulls that can be obtained are as follows: -3.0, -4.0, -5.0, -6.0, -7.0, -8.0, -9.0, -10.5, -11.5, -13.0, -14.5, -15.0, -16.5, -18.5, -21.0 dB. These DIP switch selections permit easy setup of nulls with respect to the reference input.

In systems without mix minus operation the DIP switch is used for input gain adjustment. Gains for each input range from -60 dB to +4.5 dB when not using the null operation of the card.

A jumper configures the gain of the input as from either a balanced or an unbalanced source to compensate for the gain difference so that nulling is proper.

Two jumper positions configure for expansion into and out of another 5000 card. The Expansion In is a 3 position jumper that either allows expansion into the card or shorts out



that input to the mix. The expansion out jumper banks are two 2 position jumpers. This permits feeding the internal output on this card and the expansion output bus as well.

There are two high pass filters that can be enabled or bypassed, as selected by a DIP switch. The first high pass filter has its corner frequency at 160Hz and has a slope of 12 dB/octave. The second high pass filter has its corner frequency at 315Hz and has a slope of 12dB/octave from 315Hz to 160Hz and a slope of 24dB/octave below 160Hz.

The low pass filter can be enabled or bypassed as selected by a DIP switch. Its corner frequency is 12.5kHz and has a slope of 12dB/octave.

The 5401NQ has an EQ section that can be enabled or disabled by a DIP switch. The EQ consists of three 1 Octave EQs centered at 250Hz, 500Hz and 4kHz and 5 1/3 Octave EQs centered at 800Hz, 1kHz, 1.25kHz, 1.6kHz and 2.0kHz. The gains are adjustable (10dB on the front of the 5000 rack with a trim pot. These frequencies are in the speech band for EQ adjustment mainly for voice reinforcement applications.

There is a Voltage Controlled Amplifier that can be enabled or disabled through a DIP switch setting. When enabled the overall output level can be adjusted by a control voltage introduced through an external screw terminal on the rear of the 5000 mainframe.

*Innovative Electronic Designs, Inc. • 9701 Taylorsville Road • Louisville, Kentucky 40299 • USA  
Phone: (502) 267-7436 • Fax: (502) 267-9070 • Internet: <http://www.iedaudio.com>*

## SPECIFICATIONS

### ELECTRICAL

1. Maximum Gain (all cards) . . . . .	+10.5 dB
Input to output	
2. Input Gain Range . . . . .	-6 dB - +4.5 dB
3. Maximum Input Level . . . . .	+18 dBu
4. Input Impedance, $Z_{IN}$ . . . . .	50 k $\Omega$
5. VCA Adjustment Range	
0 V . . . . .	0 dB
10 V . . . . .	90 dB
6. Maximum Output Level	
5401NQ ( $R_L \mid 600 \Omega$ ) . . . . .	+24 dBu
5401NQ-8 ( $R_L \mid 8 \Omega$ ) . . . . .	8 V rms
7. Frequency Response, 20 Hz - 20 kHz' . . . . .	( 0.2 dB
EQ, High pass filter, Low Pass Filter bypassed	
8. Total Harmonic Distortion, THD	
VCA set for unity gain	
5401NQ (+18 dBu) . . . . .	< 0.1 %
5401NQ-8 (8 W, $R_L = 8\Omega$ ) . . . . .	< 0.3 %
9. Signal-to-Noise Ratio, S/N	
(20 Hz - 20 kHz filters)	
5401NQ (unity gain, referred to +4 dBu) . . . . .	>85 dB
5401NQ-8 (8 W reference)	

### MECHANICAL

1. Size (maximum Overall Dimensions)	
Height . . . . .	2.8"
Width . . . . .	1.25"
Depth . . . . .	8.4"
2. Weight	
5401NQ . . . . .	.50lb
5401NQ-8 . . . . .	.48lb
5401NE . . . . .	.38lb

### ENVIRONMENTAL

1. Operating Temperature Range . . . . .	(+32>F - +131>F) 0>C - +55>C
2. Storage Temperature Range . . . . .	(-40>F - +158>F) -40>C - +70>C



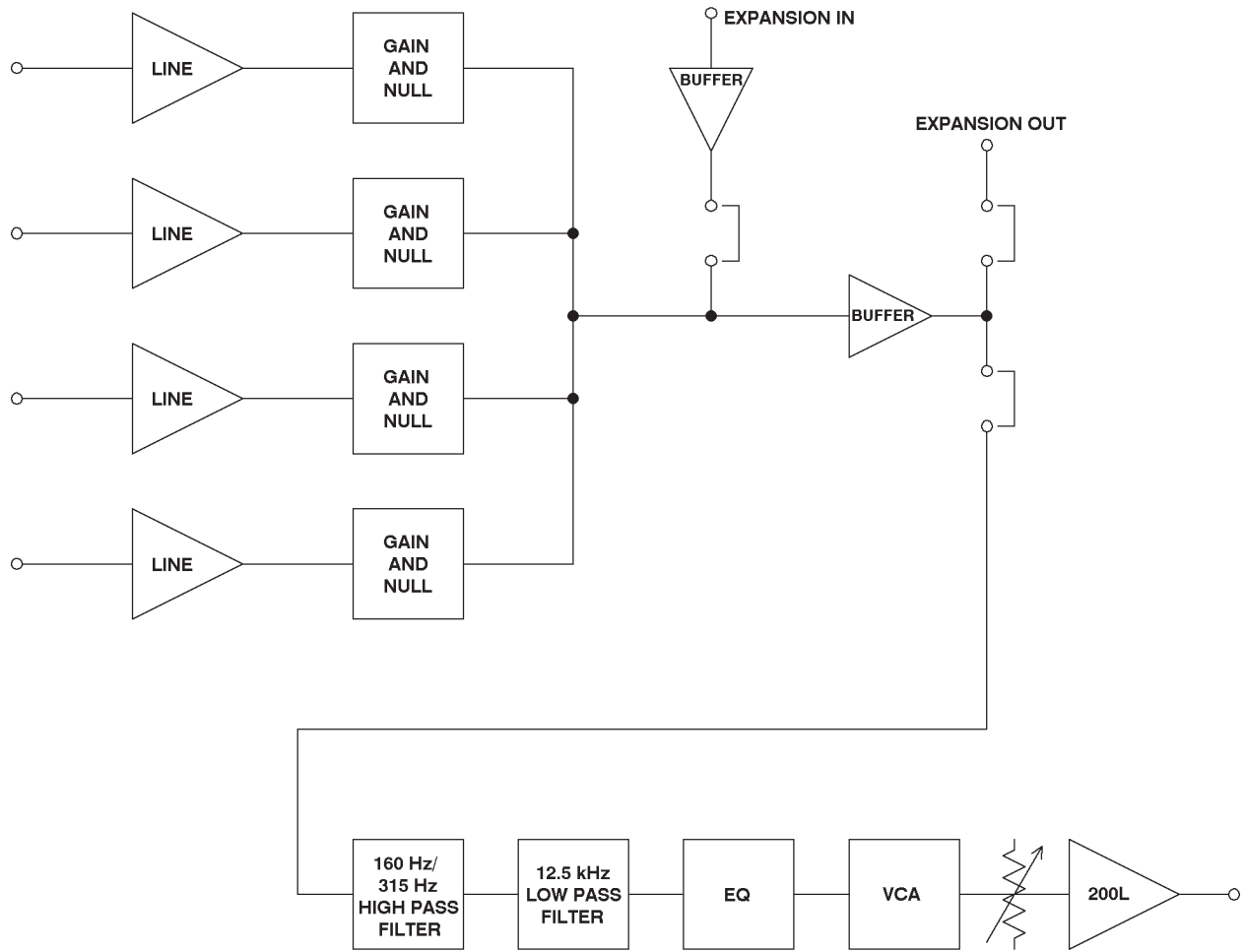

Figure 1 - 5401NQ Block Diagram

*Innovative Electronic Designs, Inc. • 9701 Taylorsville Road • Louisville, Kentucky 40299 • USA  
 Phone: (502) 267-7436 • Fax: (502) 267-9070 • Internet: <http://www.iedaudio.com>*

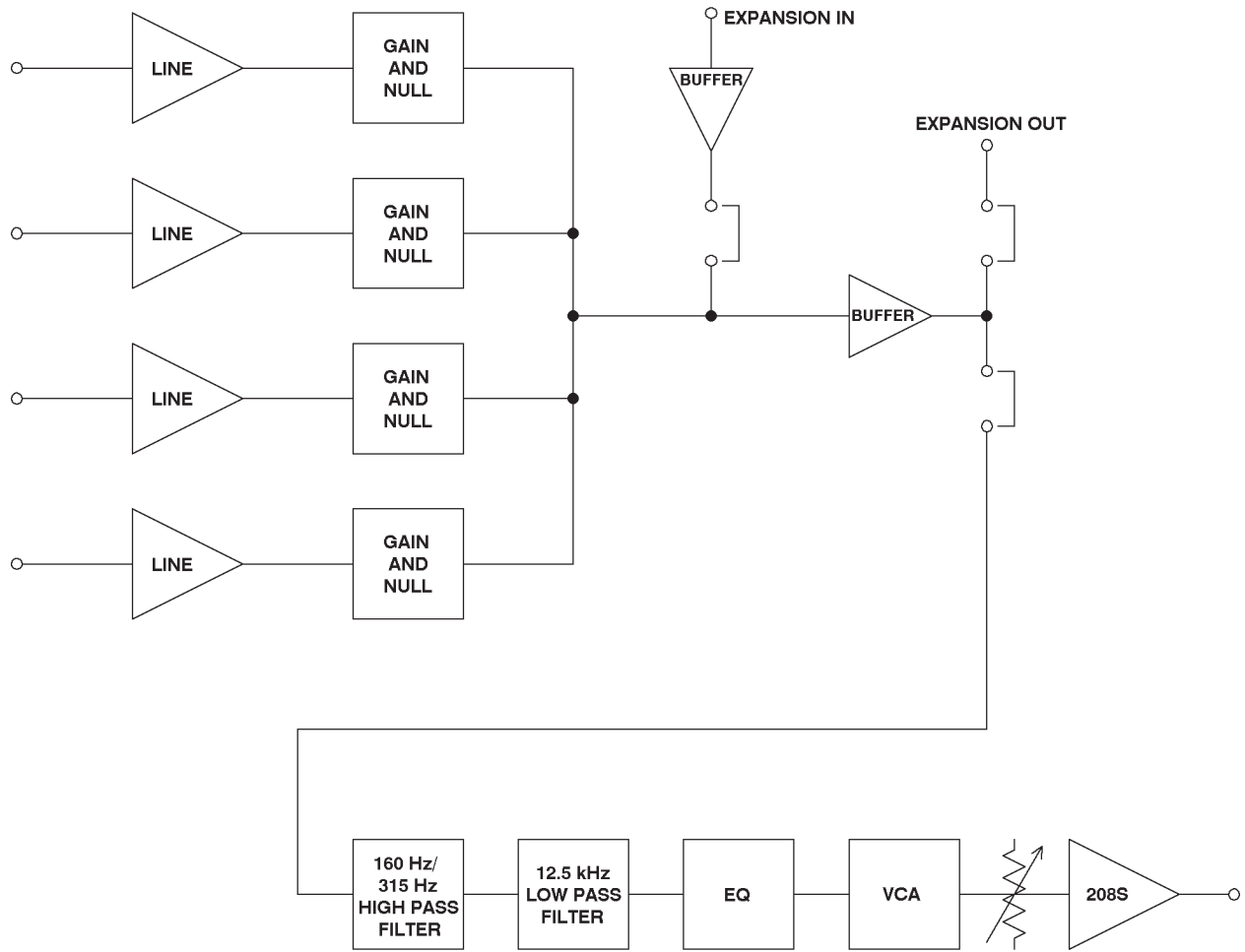

Figure 2 - 5401NQ-8 Block Diagram

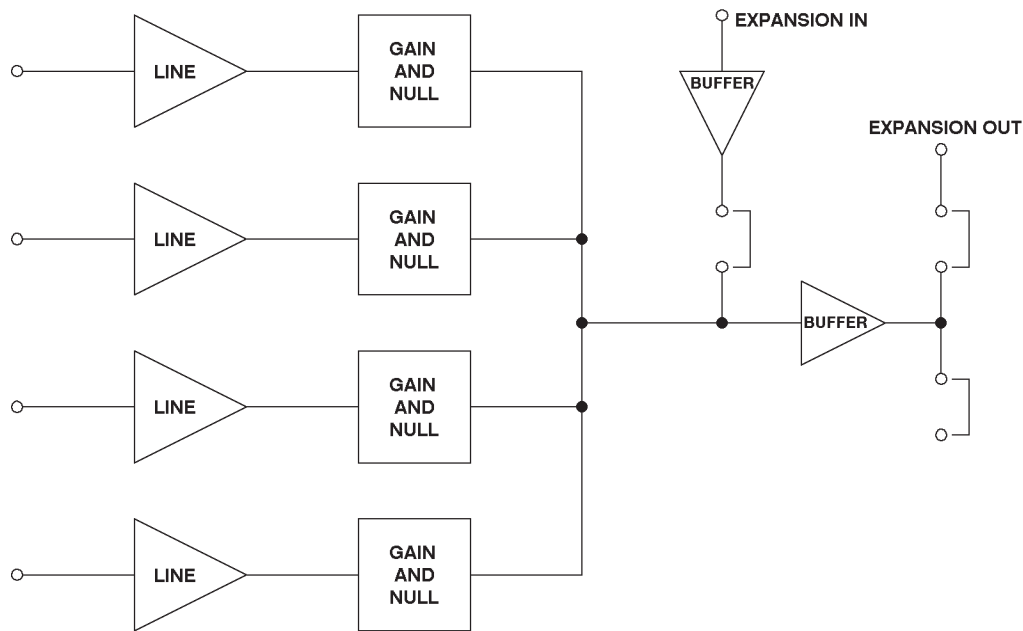

Figure 3 - 5401NE Block Diagram

*Innovative Electronic Designs, Inc. • 9701 Taylorsville Road • Louisville, Kentucky 40299 • USA  
Phone: (502) 267-7436 • Fax: (502) 267-9070 • Internet: <http://www.iedaudio.com>*