

---

**5201VS, 5201VS-8, 5251VS, 5101VS, 5101VS-8, 5151VS**

---

**TWO INPUT, ONE OUTPUT MIXER CARDS WITH  
VOLTAGE CONTROLLED AMPLIFIER (VCA) AND SWITCH**

---

---

**GENERAL PROCEDURE**

---

- » **BEFORE REMOVING OR INSERTING CIRCUIT CARDS, TURN OFF THE POWER, EITHER BY TURNING OFF THE AC POWER TO THE MAINFRAME, BY TURNING OFF THE SWITCH ON THE 5030/5030P POWER SUPPLY, OR BY TURNING OFF THE SWITCH ON THE 5002 EXTERNAL POWER SUPPLY INTERFACE CARD. FAILURE TO DO SO MAY RESULT IN DAMAGE TO THE CARDS AND WILL VOID THE WARRANTY.**

Installation of the cards consists of the following steps:

1. Locate a proper slot in the mainframe. Mainframe slots are set up on the rear panel of the mother board according to the card type to be used. Slots are dedicated by installing the proper trimpots. Trimpots **MUST** be installed as indicated in Figure 2 and 3 for inputs and outputs to function. Microphone level inputs require 200 $\Omega$  trimpots. All others require 10 k $\Omega$  trimpots. Slots labels are applied at the factory above each slot position. Single input cards such as the 5101VS, 5101VS-8, 5151VS, and are labeled 'SPECIAL', as are any specially made cards. With the exception of the SPECIALs, cards may be inserted in any slot with a matching label.
2. Start the card in the slot with the components to the right and the card ejector on top. Raise the card ejector to the horizontal position and slide the card in until it contacts the connector. Release the card ejector. See that the upper tip enters the groove in the bottom edge of the horizontal bar. Complete the insertion by pressing the card inward while pressing down on the card ejector. When the card is properly seated the card ejector lever should be in a vertical position with the upper tip still in the groove in the horizontal bar.

Card removal:

1. Grasp the lower end of the card ejector lever and swing it outward and upward to free the card from the card edge connector.
2. Slide the card outward until it is free of the slot.

---

**EXPANSION**

---

If more inputs and/or outputs are needed than are available on the circuit card being used they may be added by making use of the expansion feature of the 5000 Series.

To add inputs, place the Expansion/Normal jumper of the card which is to receive the inputs in the Expansion position. Install the card which is to provide the additional inputs (input expansion card) in the mainframe slot to the left of the card receiving the inputs (as viewed from the front of the mainframe). The card receiving the inputs will mix their signal with its own so that the combined signals will appear at its output. If still more in-



puts are needed, add another input expansion card to the left of the first one, and place the Expansion/Normal jumper of the first expansion card in the expansion position. This process may be repeated as long as slots are available for the expansion cards.

To add outputs, move the Expansion/Normal jumper of the card which is to provide the additional outputs to the expansion position, then install it in the slot to the right (as viewed from the front) of the card requiring the additional outputs. If still more outputs are required, repeat the process, installing the second output expansion card to the right of the first one.

It is not necessary for the card used for expansion to be of the same type, or even the same group, as the card receiving the expansion. Almost any 5000 series card may be used for expansion. In most cases it may be advantageous to use a card of a different type. For example, when adding inputs, the normal outputs on the expansion cards are frequently not used. By using an expansion card which has the output module omitted, a cost saving may be realized. Cards intended for expansion, and having the unused inputs or outputs omitted are designated with an 'E' suffix.

There are some exceptions to the general rules for expansion given above. The 5202S and the 5252S have no provisions for expansion, either in or out. The 5401 types, the 5104 types, and the 5202 types have both an Expansion Out and an Expansion In jumper. To receive inputs from the card to the left, these types must have their Expansion In jumpers in the Expansion position. To route outputs to the card to the right, they must have their Expansion Out jumpers in the Expansion position.

## GAIN STRUCTURE

The gain structure diagrams in Figures 2 - 3 show the signal levels and gains or losses at key points in the cards. Since all outputs on a card behave identically, only one output is shown in the diagrams. In the examples the Input Gain Adjust pots were set for minimum

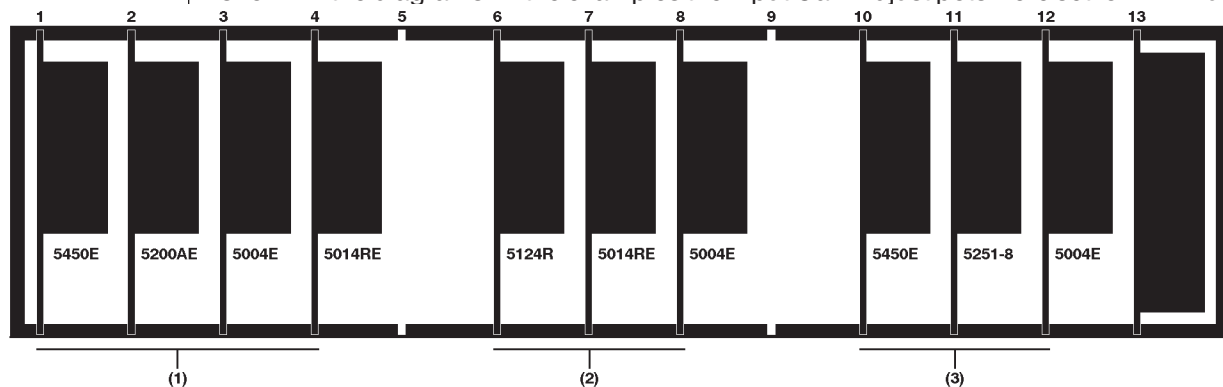

Example 1 - 4 microphone level inputs, 2 line level inputs with VCDA, 4 line level outputs, and 4 microphone level outputs

Example 2 - 1 microphone level input distributed to 8 microphone level outputs and 4 line level outputs

Example 3 - 6 microphone level inputs mixed to 4 line level outputs and 1 8  $\Omega$ , 8 W speaker output

Figure 1 - Input/Output Expansion Examples

*Innovative Electronic Designs, Inc. • 9701 Taylorsville Road • Louisville, Kentucky 40299 • USA  
Phone: (502) 267-7436 • Fax: (502) 267-9070 • Internet: <http://www.iedaudio.com>*

gain (fully counterclockwise), and the Output Level Adjust pots at maximum output (fully counterclockwise). The levels and gains shown are those required to produce an output level of 0 dBu.

NOTE: The numbers below represent levels or gains/losses at the points in the circuit directly below them. Numbers In Parentheses Are Gains Or Losses.

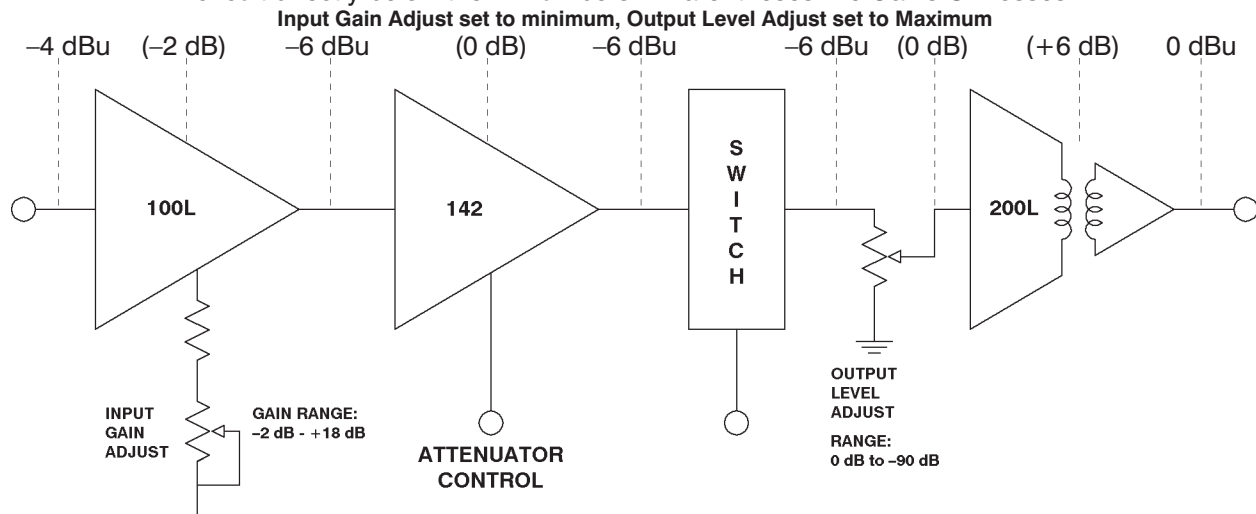

Figure 2 - Gain Structure  
5101VS, 5201VS

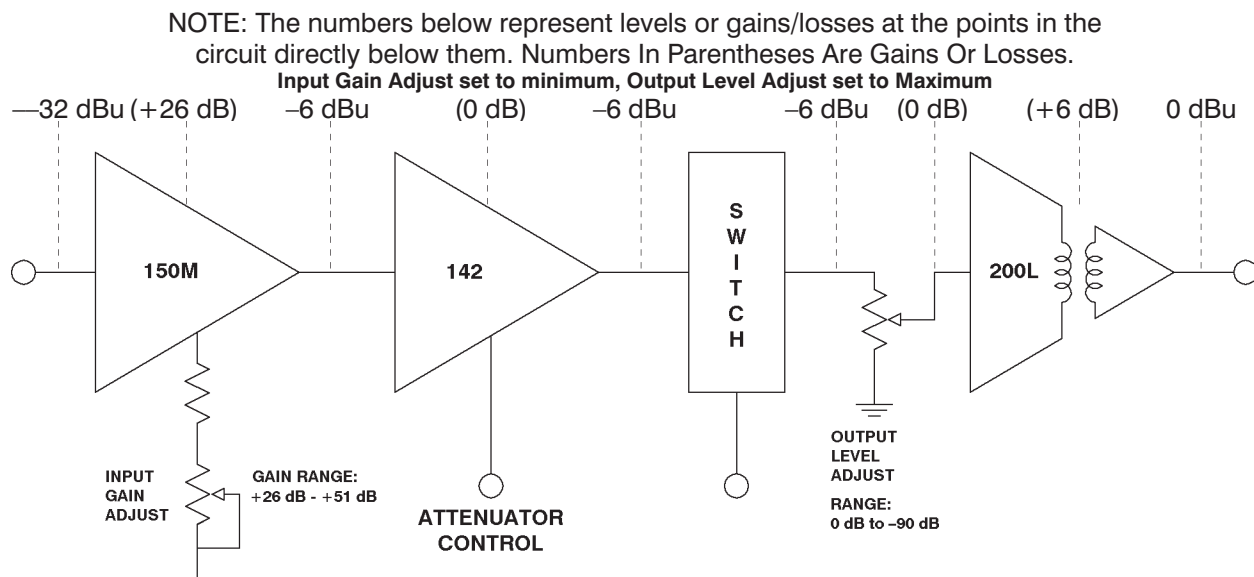

Figure 3 - Gain Structure  
 5151VS, 5251VS

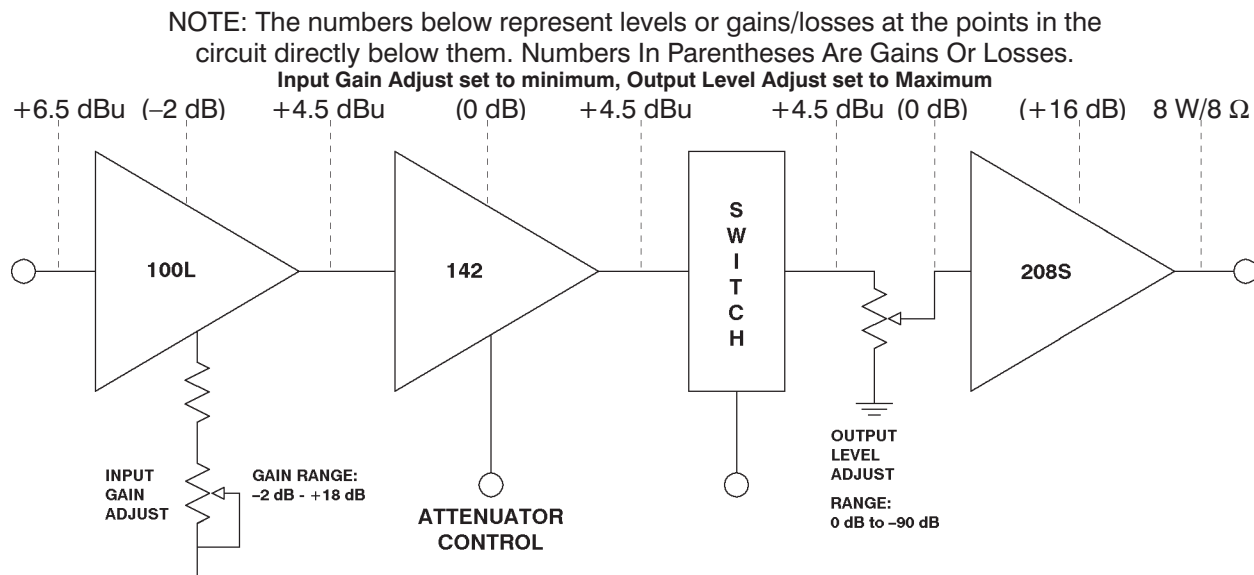

Figure 4 - Gain Structure  
 5101VS-8, 5201VS-8

*Innovative Electronic Designs, Inc. • 9701 Taylorsville Road • Louisville, Kentucky 40299 • USA  
 Phone: (502) 267-7436 • Fax: (502) 267-9070 • Internet: <http://www.iedaudio.com>*

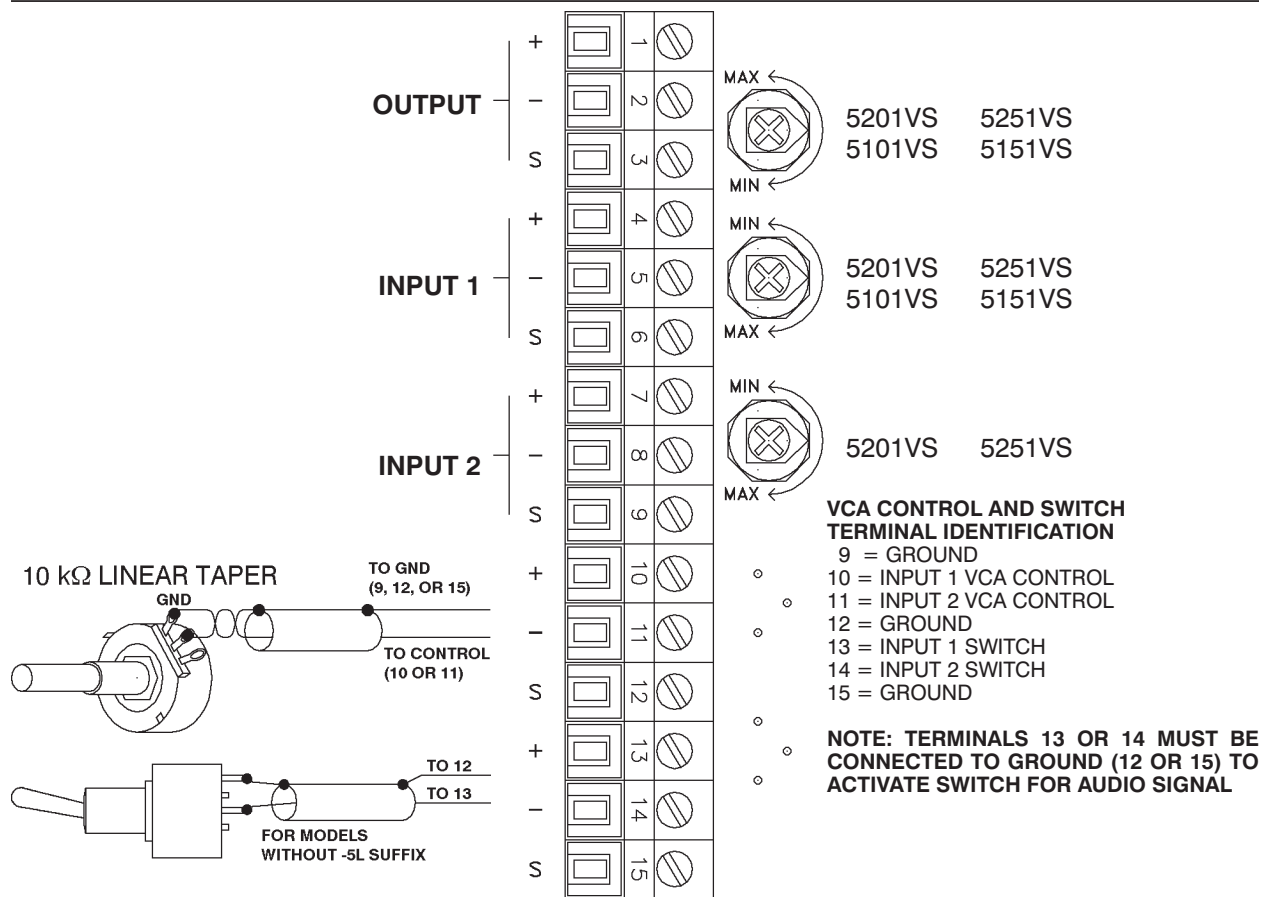

Figure 5 - 5032 Rear Panel Terminal Connections  
5201VS, 5251VS, 5101VS, 5151VS

**NOTES:**

1. Output trimpot increases level with counterclockwise rotation.
2. Input trimpots for microphone level inputs (5251VS, 5151VS) are 200 Ω. All other trimpots are 10 kΩ
3. High sides of inputs or outputs are marked '+'. Low sides are marked '-'. Shield terminals are marked 'S', and are grounded on the mother board.
4. When connecting to the compression-type screw terminal connectors, use tinned stranded wire between 14 and 22 AWG. Be sure that all strands enter the terminal, so that there is no possibility of their shorting to an adjacent terminal. **DO NOT APPLY EXTRA TINNING!** Extra tinning can result in long term loosening of the connections, resulting in erratic operation and failure.
5. 5101VS, and 5151VS do not have Input 2 terminal connections or Input 2 trimpot.



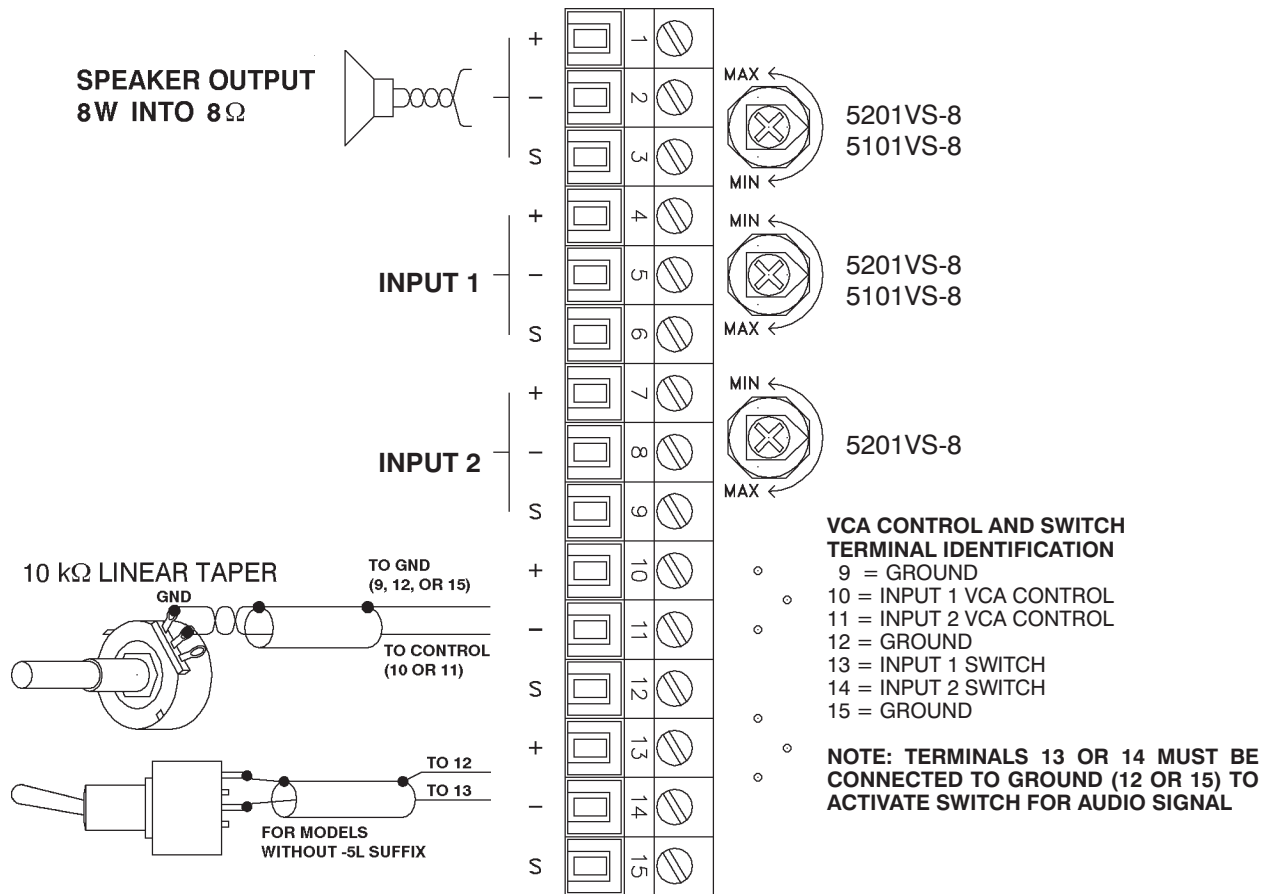

Figure 6 - 5032 Rear Panel Terminal Connections  
 5201VS-8, 5101VS-8

**NOTES:**

1. Output trimpot increases level with counterclockwise rotation.
2. All trimpots are 10 kΩ
3. High sides of inputs or outputs are marked '+'. Low sides are marked '-'. Shield terminals are marked 'S', and are grounded on the mother board.
4. When connecting to the compression-type screw terminal connectors, use tinned stranded wire between 14 and 22 AWG. Be sure that all strands enter the terminal, so that there is no possibility of their shorting to an adjacent terminal. **DO NOT APPLY EXTRA TINNING!** Extra tinning can result in long term loosening of the connections, resulting in erratic operation and failure.
5. 5101VS-8 does not have Input 2 terminal connections or Input 2 trimpot.
6. Speakers are connected to terminals 1 and 2.

*Innovative Electronic Designs, Inc. • 9701 Taylorsville Road • Louisville, Kentucky 40299 • USA*  
*Phone: (502) 267-7436 • Fax: (502) 267-9070 • Internet: <http://www.iedaudio.com>*

SOLDER SIDE			COMPONENT SIDE		
PIN <sup>1</sup>	TRM <sup>2</sup>	FUNCTION	PIN <sup>1</sup>	TRM <sup>2</sup>	FUNCTION
1.		+15 VDC Regulated	2.		+15 VDC Regulated
3.		Expansion Input	4.		Expansion Output
5.		Output Trimpot Counterclockwise End	6.		Output Trimpot Wiper
7.		Output Trimpot Clockwise End <sup>4</sup>	8.		Ground <sup>3</sup>
9.	1	Output +	10.	2	Output –
11.		Input 1 Trimpot Counterclockwise End	12.		Input 1 Trimpot Wiper
13.		Input 1 Trimpot Clockwise End	14.		Ground <sup>3</sup>
15.	4	Input 1 +	16.	5	Input 1 –
17.		Ground <sup>3</sup>	18.		Ground <sup>3</sup>
19.		Input 2 Trimpot Counterclockwise End <sup>5</sup>	20.		Input 2 Trimpot Wiper <sup>5</sup>
21.		Input 2 Trimpot Clockwise End <sup>5</sup>	22.		Ground <sup>3</sup>
23.	7	Input 2 + <sup>5</sup>	24.	8	Input 2 – <sup>5</sup>
25.		Ground <sup>3</sup>	26.		Ground <sup>3</sup>
27.		Not used	28.		Not used
29.		Not used	30.		Ground <sup>3</sup>
31.	10	Input 1 VCA Control	32.	11	Input 2 VCA Control <sup>5</sup>
33.		Ground <sup>3</sup>	34.		Ground <sup>3</sup>
35.		Not used	36.		Not used
37.		Not used	38.		Ground <sup>3</sup>
39.	13	Input 1 Switch Control	40.	14	Input 2 Switch Control <sup>5</sup>
41.		Phantom Powering Voltage +15 VDC or +48 VDC, Maximum	42.		Phantom Powering Voltage +15 VDC or +48 VDC, Maximum
43.		–15 VDC Regulated	44.		–15 VDC Regulated
<p>NOTE 1 - PIN = Card edge connector terminal  NOTE 2 - TRM = Rear panel screw terminal  NOTE 3 - All ground connections are common on the card and on the 5032 motherboard ground plane.  NOTE 4 - Connected to ground on this card.  NOTE 5 - Not used with 5101VS, 5151VS, 5101VS-8</p>					
Table 1 - Card Edge Connector Pin Assignments					

This page left blank intentionally

*Innovative Electronic Designs, Inc. • 9701 Taylorsville Road • Louisville, Kentucky 40299 • USA  
Phone: (502) 267-7436 • Fax: (502) 267-9070 • Internet: <http://www.iedaudio.com>*