5201PS, 5201PS-8, 5251PS, 5101PS, 5151PS, 5151PS-8

**TWO INPUT, ONE OUTPUT MIXER CARDS WITH
PROGRAMMABLE GAIN CONTROL (PGC) AND SWITCH**

GENERAL PROCEDURE

- >> BEFORE REMOVING OR INSERTING CIRCUIT CARDS, TURN OFF THE POWER, EITHER BY TURNING OFF THE AC POWER TO THE MAINFRAME, BY TURNING OFF THE SWITCH ON THE 5030/5030P POWER SUPPLY, OR BY TURNING OFF THE SWITCH ON THE 5002 EXTERNAL POWER SUPPLY INTERFACE CARD. FAILURE TO DO SO MAY RESULT IN DAMAGE TO THE CARDS AND WILL VOID THE WARRANTY.**

Installation of the cards consists of the following steps:

1. Locate a proper slot in the mainframe. Mainframe slots are set up on the rear panel of the mother board according to the card type to be used. Slots are dedicated by installing the proper trimpots. Trimpots **MUST** be installed as indicated in Figure 2 and 3 for inputs and outputs to function. Microphone level inputs require 200 Ω trimpots. All others require 10 k Ω trimpots. Slots labels are applied at the factory above each slot position. Single input cards such as the 5101PS, 5101PS-8, and the 5151PS are labeled 'SPECIAL', as are any specially made cards. With the exception of the SPECIALs, cards may be inserted in any slot with a matching label.
2. Start the card in the slot with the components to the right and the card ejector on top. Raise the card ejector to the horizontal position and slide the card in until it contacts the connector. Release the card ejector. See that the upper tip enters the groove in the bottom edge of the horizontal bar. Complete the insertion by pressing the card inward while pressing down on the card ejector. When the card is properly seated the card ejector lever should be in a vertical position with the upper tip still in the groove in the horizontal bar.

Card removal:

1. Grasp the lower end of the card ejector lever and swing it outward and upward to free the card from the card edge connector.
2. Slide the card outward until it is free of the slot.

EXPANSION

If more inputs and/or outputs are needed than are available on the circuit card being used they may be added by making use of the expansion feature of the 5000 Series.

To add inputs, place the Expansion/Normal jumper of the card which is to receive the inputs in the Expansion position. Install the card which is to provide the additional inputs (input expansion card) in the mainframe slot to the left of the card receiving the inputs (as viewed from the front of the mainframe). The card receiving the inputs will mix their signal with its own so that the combined signals will appear at its output. If still more in-



puts are needed, add another input expansion card to the left of the first one, and place the Expansion/Normal jumper of the first expansion card in the expansion position. This process may be repeated as long as slots are available for the expansion cards.

To add outputs, move the Expansion/Normal jumper of the card which is to provide the additional outputs to the expansion position, then install it in the slot to the right (as viewed from the front) of the card requiring the additional outputs. If still more outputs are required, repeat the process, installing the second output expansion card to the right of the first one.

It is not necessary for the card used for expansion to be of the same type, or even the same group, as the card receiving the expansion. Almost any 5000 series card may be used for expansion. In most cases it may be advantageous to use a card of a different type. For example, when adding inputs, the normal outputs on the expansion cards are frequently not used. By using an expansion card which has the output module omitted, a cost saving may be realized. Cards intended for expansion, and having the unused inputs or outputs omitted are designated with an 'E' suffix.

There are some exceptions to the general rules for expansion given above. The 5202S and the 5252S have no provisions for expansion, either in or out. The 5401 types, the 5104 types, and the 5202 types have both an Expansion Out and an Expansion In jumper. To receive inputs from the card to the left, these types must have their Expansion In jumpers in the Expansion position. To route outputs to the card to the right, they must have their Expansion Out jumpers in the Expansion position.

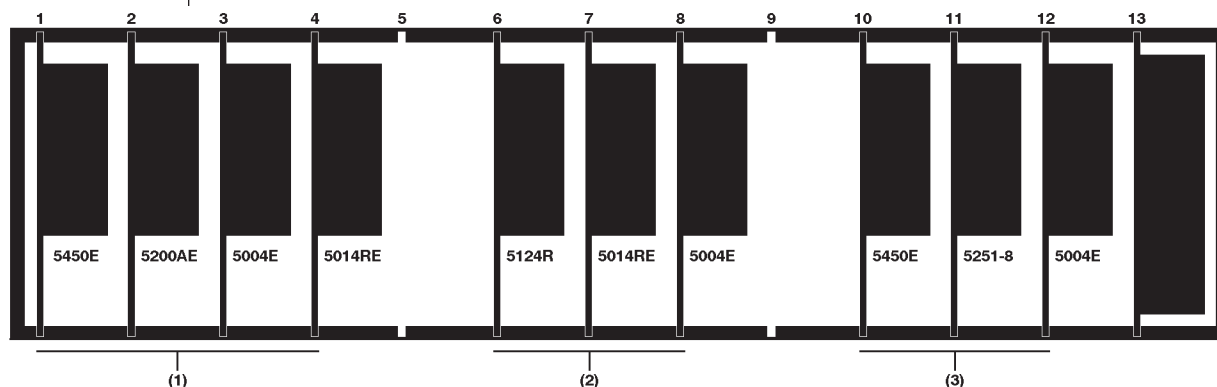

Example 1 - 4 microphone level inputs, 2 line level inputs with VCDA, 4 line level outputs, and 4 microphone level outputs

Example 2 - 1 microphone level input distributed to 8 microphone level outputs and 4 line level outputs

Example 3 - 6 microphone level inputs mixed to 4 line level outputs and 1 8 Ω, 8 W speaker output

Figure 1 - Input/Output Expansion Examples

*Innovative Electronic Designs, Inc. • 9701 Taylorsville Road • Louisville, Kentucky 40299 • USA
 Phone: (502) 267-7436 • Fax: (502) 267-9070 • Internet: <http://www.iedaudio.com>*

GAIN SETUP

120P PROGRAMMABLE GAIN CONTROL (PGC) DEFINITION OF TERMS AND DESCRIPTION OF OPERATION

The 120P is a unique device, proprietary to IED, for automatically adjusting and maintaining its output at an almost constant level without the signal degradation which is inherent in other devices such as compressors. Level is adjusted automatically at a rate comparable to a trained operator at a console. Four parameters which help describe its operation, Sampling Threshold, Gain Reduction Threshold, Gain Increase Time, and Gain Decrease Time, are defined below.

SAMPLING THRESHOLD

The Sampling Threshold is the input level to the 120P Module above which it samples the input signal level, notes any changes from the last sample, and makes a decision as to how much and in which direction to adjust its gain. The value of the Sampling Threshold of the 120P is -32 dBu. If the input signal level remains above the Sampling Threshold, but below the Gain Reduction Threshold (-18 dBu, see below), the gain of the 120P will gradually increase to its maximum value of 20 dB. While operating in this region, the gain cannot decrease. When the input signal drops below the Sampling Threshold, the gain is held constant indefinitely at its last value (as long as power to the module is maintained). When the input signal once again exceeds the Sampling Threshold, the gain will still be at the last value as it was before the signal dropped below the Sampling Threshold, and will be readjusted from there in accordance with the current input signal level.

GAIN REDUCTION THRESHOLD

The Gain Reduction Threshold is the input level to the 120P Module above which its internal circuitry reduces its gain to maintain its average output at a nearly constant level. The value of the Gain Reduction Threshold of the 120P is -18 dBu. As the input signal increases above the Gain Reduction Threshold, the gain of the 120P will be reduced until the input signal reaches the maximum allowable value of $+21$ dBu. Between the input levels of -18 dBu and $+21$ dBu the output of the 120P will increase from $+2$ dBu to $+7$ dBu, a change of only 5 dBu.

GAIN DECREASE TIME

The Gain Decrease Time is the time required for the 120P to decrease its gain to the new steady state value in response to a step increase in signal level. When a step increase of 20 dBu (-18 dBu to $+2$ dBu) of a sine wave signal is applied to the input, the gain will correct to the new value in 2.5 seconds. As a corollary of the above definition, if a varying signal which exceeds the reduction threshold 30% of the time is applied to the input, in 2.5 seconds, the 120P will reach 30% of the gain reduction which would be achieved with a continuous signal. This is true because gain decreases occur only during the time when the signal exceeds the Gain Reduction Threshold.

GAIN INCREASE TIME

The Gain Increase Time is the time required for the 120P to increase its gain to the new steady state value in response to a step decrease in signal level. When a step decrease of 20 dBu ($+2$ dBu to -18 dBu) of a sine wave signal is applied to the input, the gain will correct to the new value in 7 seconds. As a corollary of the above definition, if a varying signal which exceeds the Sampling Threshold 30% of the time is applied to the input, in



7 seconds, the 120P will reach 30% of the gain reduction which would be achieved with a continuous signal. This is true because gain increases occur only during the time when the signal exceeds the Sampling Threshold.

GAIN SETUP EXAMPLES

OVERVIEW

As described above, the 120P adjusts its gain to maintain its output at an almost constant level over an input signal range of -18 dBu to $+21$ dBu. To take advantage of the capabilities of the 120P, the gain structure of the card containing the 120P must be set up so that over the normal operating range the input of the 120P remains within these limits. This is most easily accomplished by setting the input gain adjustment of the 100L so that at the minimum usable input level to the card, the input to the 120P will be at -18 dBu. The output level adjustment pot is then set so that the card output is at the desired line level, usually in the range of 0 to $+4$ dBu.

GAIN SETUP FOR 5201PS, 5101PS

The levels, gain values, and controls referred to in the following examples are illustrated in Figure .

Example 1. - The input to the card is the output of a typical Hi Fi type tape recorder with a lowest normal usable signal level of -25 dBu. Set the 100L gain to 7 dB by adjusting the Input Gain Adjustment Trimpot. This will increase the -25 dBu signal to -18 dBu (the Gain Reduction Threshold of the 120P). Set the Output Level Adjust Trimpot 8 dB down from maximum (maximum is fully counterclockwise) to produce a normal output of 0 to $+3$ dBu with input signals varying between -25 dBu and 0 dBu.

NOTE: The numbers below represent levels or gains/losses at the points in the circuit directly below them. Numbers In Parentheses Are Gains Or Losses.

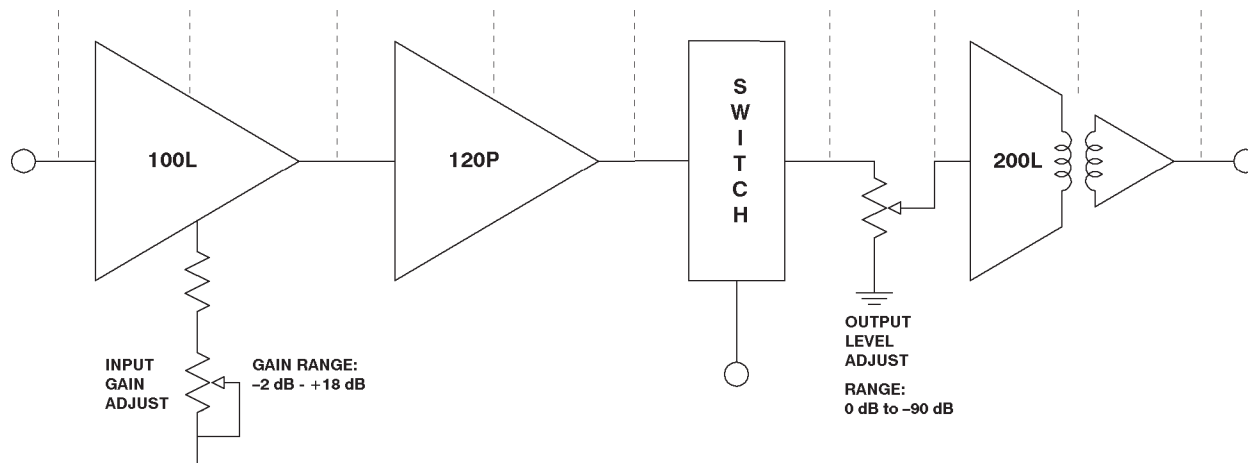

Figure 2 - Gain Setup Example 1
 5101PS, 5201PS

Innovative Electronic Designs, Inc. • 9701 Taylorsville Road • Louisville, Kentucky 40299 • USA
Phone: (502) 267-7436 • Fax: (502) 267-9070 • Internet: <http://www.iedaudio.com>

GAIN SETUP FOR 5251PS, 5151PS

The levels, gain values, and controls referred to in the following examples are illustrated in Figure .

Example 2. - The input to the card is the output of a dynamic type microphone. When used at a distance of 12 inches, the normal lowest usable output signal level is -65 dBu. At this condition, set the 150M gain to 47 dB by adjusting the Input Gain Adjustment Trimpot. This will increase the -65 dBu signal to -18 dBu (the Gain Reduction Threshold of the 120P). Set the Output Level Adjust Trimpot 8 dB down from maximum (maximum is fully counterclockwise) to produce a normal output of 0 to +3 dBu with input signals varying between -65 dBu and -40 dBu.

NOTE: The numbers below represent levels or gains/losses at the points in the circuit directly below them. Numbers In Parentheses Are Gains Or Losses.

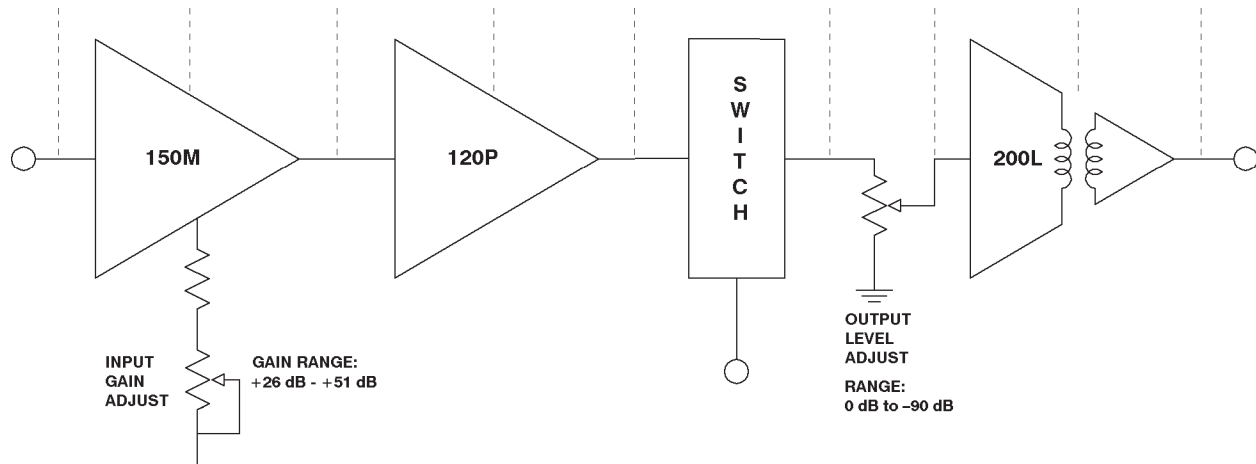

Figure 3 - Gain Setup Example 2
5251PS, 5151PS

GAIN STRUCTURE

The gain structure diagrams in Figures 4 - 6 show the signal levels and gains or losses at key points in the cards. Since all inputs on a card behave identically, only one input is shown in the diagrams. In the examples the Input Gain Adjust pots were set for minimum gain (fully counterclockwise), and the Output Level Adjust pots at maximum output (fully counterclockwise). The levels and gains shown are those required to produce an output level of 0 dBu.



NOTE: The numbers below represent levels or gains/losses at the points in the circuit directly below them. Numbers In Parentheses Are Gains Or Losses.
Input Gain Adjust set to minimum, Output Level Adjust set to Maximum

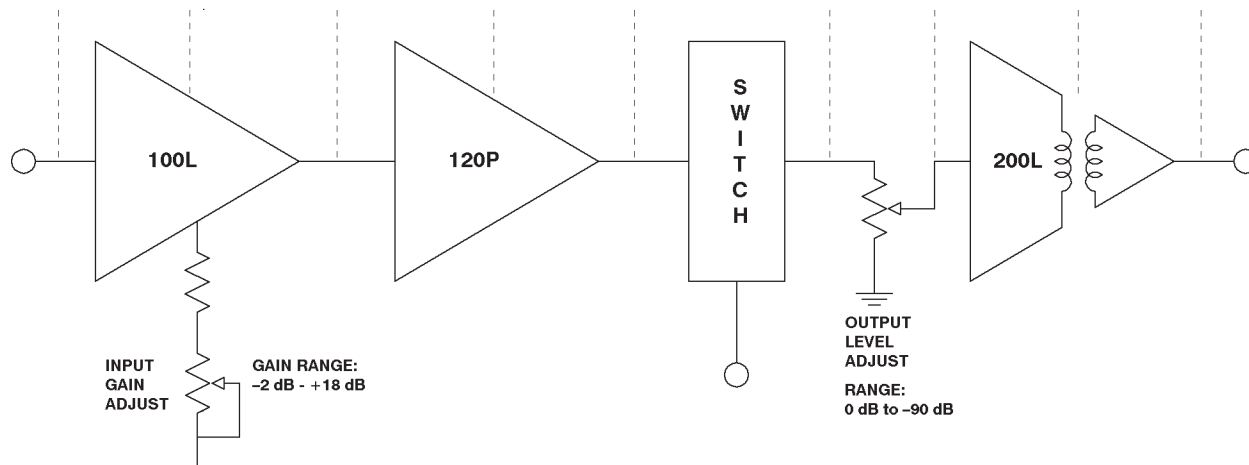

Figure 4 - Gain Structure
5101PS, 5201PS

NOTE: The numbers below represent levels or gains/losses at the points in the circuit directly below them. Numbers In Parentheses Are Gains Or Losses.
Input Gain Adjust set to minimum, Output Level Adjust set to Maximum

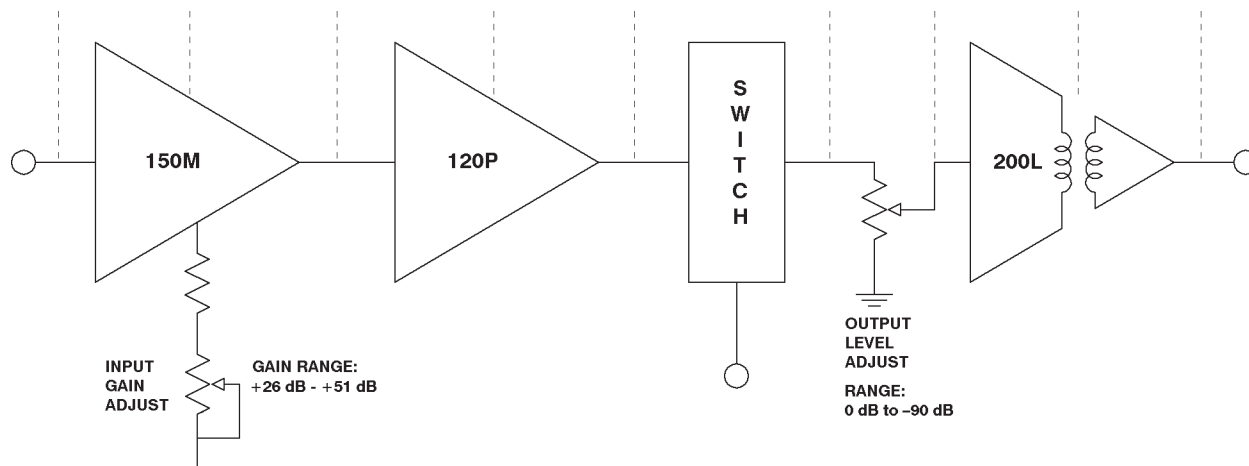

Figure 5 - Gain Structure
5251PS, 5151PS

*Innovative Electronic Designs, Inc. • 9701 Taylorsville Road • Louisville, Kentucky 40299 • USA
Phone: (502) 267-7436 • Fax: (502) 267-9070 • Internet: <http://www.iedaudio.com>*

NOTE: The numbers below represent levels or gains/losses at the points in the circuit directly below them. Numbers In Parentheses Are Gains Or Losses.
Input Gain Adjust set to minimum, Output Level Adjust set to Maximum

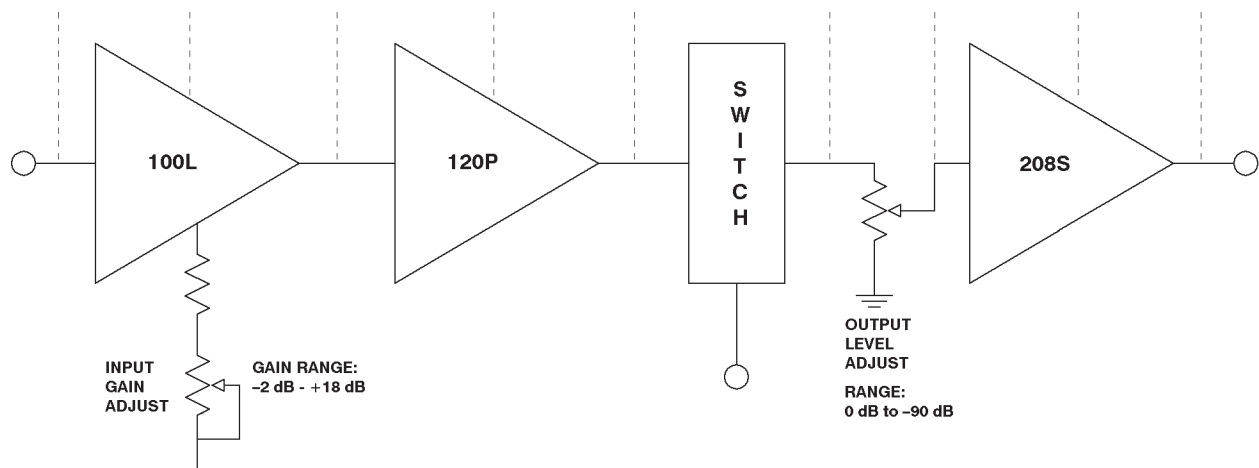

Figure 6 - Gain Structure
5101PS-8, 5201PS-8

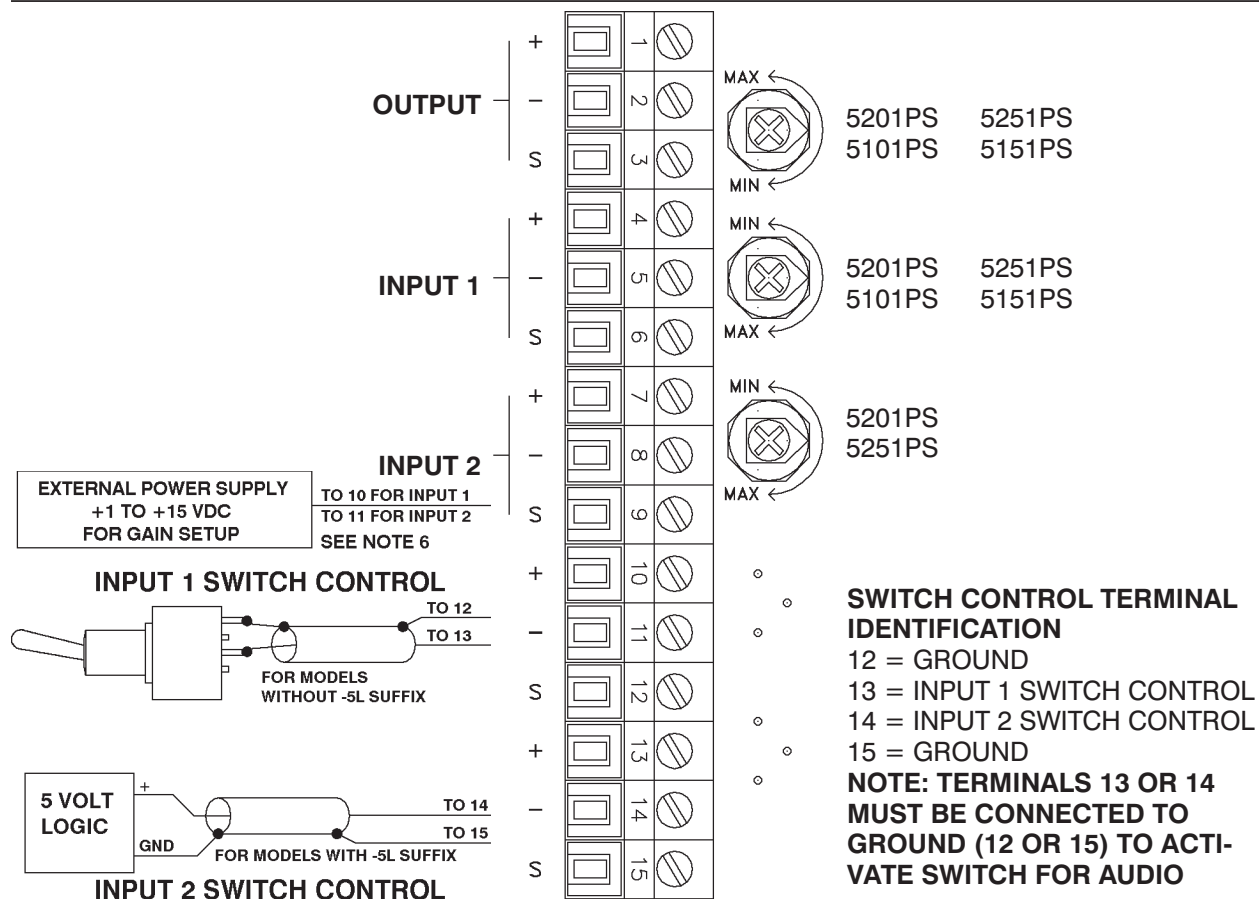

Figure 7 - 5032 Rear Panel Terminal Connections
5251PS, 5251PS, 5101PS, 5151PS

NOTES:

1. Output trimpot increases level with counterclockwise rotation.
2. Input trimpots for microphone level inputs (5251PS, 5151PS) are 200 Ω. All other trimpots are 10 kΩ
3. High sides of inputs or outputs are marked '+'. Low sides are marked '-'. Shield terminals are marked 'S', and are grounded on the mother board.
4. When connecting to the compression-type screw terminal connectors, use tinned stranded wire between 14 and 22 AWG. Be sure that all strands enter the terminal, so that there is no possibility of their shorting to an adjacent terminal. **DO NOT APPLY EXTRA TINNING!** Extra tinning can result in long term loosening of the connections, resulting in erratic operation and failure.
5. 5101PS and 5151PS do not have Input 2 terminal connections or Input 2 trimpot.
6. To force the 120P to maximum gain (20 dB) for gain setup, connect a 1 V to 15 V power supply as shown, between terminal 10 or 11 and any 'S' terminal.

Innovative Electronic Designs, Inc. • 9701 Taylorsville Road • Louisville, Kentucky 40299 • USA
Phone: (502) 267-7436 • Fax: (502) 267-9070 • Internet: <http://www.iedaudio.com>

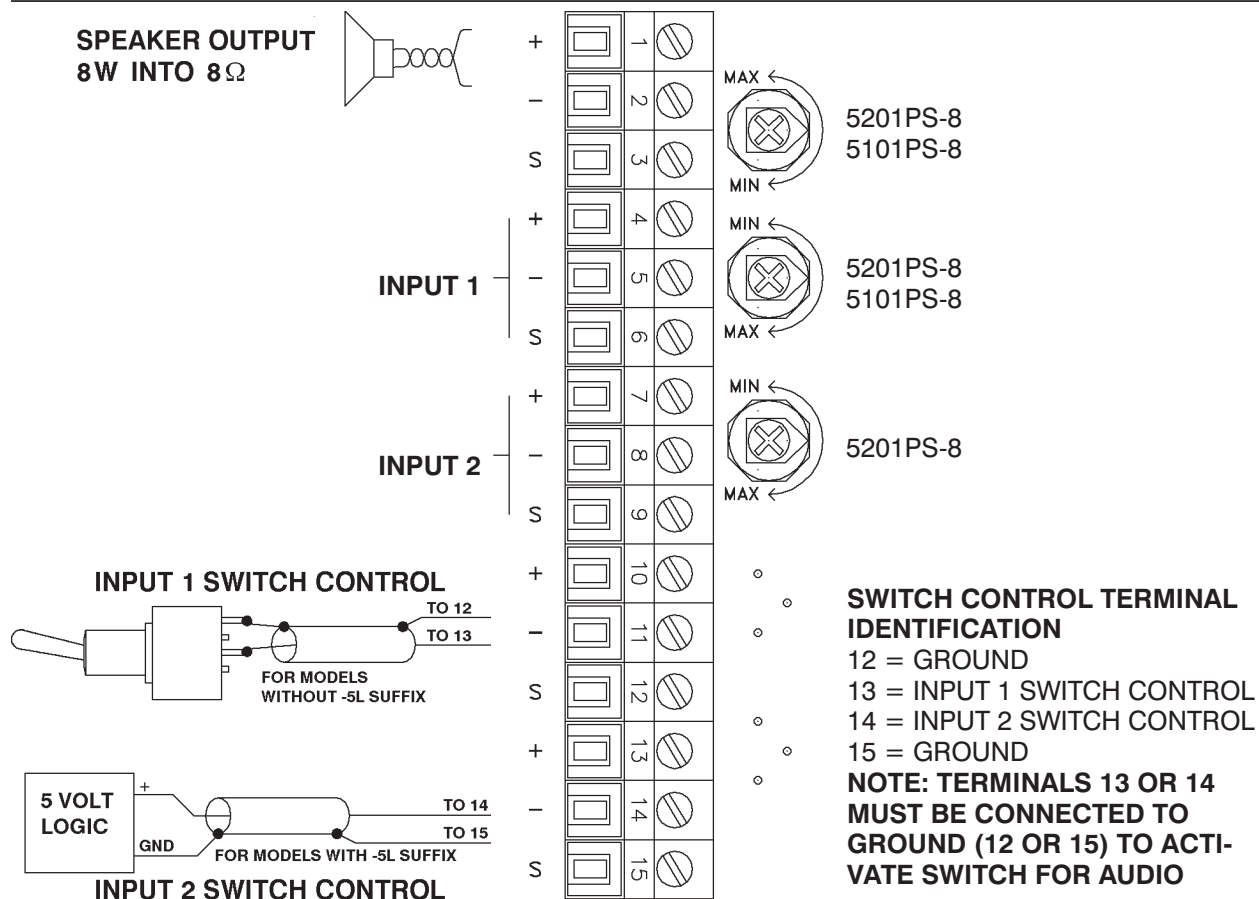

Figure 8 - 5032 Rear Panel Terminal Connections
5201PS-8, 5101PS-8

NOTES:

1. Output trimpot increases level with counterclockwise rotation.
- 2 All trimpots are 10 kΩ
3. High sides of inputs or outputs are marked '+'. Low sides are marked '-'. Shield terminals are marked 'S', and are grounded on the mother board.
4. When connecting to the compression-type screw terminal connectors, use tinned stranded wire between 14 and 22 AWG. Be sure that all strands enter the terminal, so that there is no possibility of their shorting to an adjacent terminal. **DO NOT APPLY EXTRA TINNING!** Extra tinning can result in long term loosening of the connections, resulting in erratic operation and failure.
5. 5101PS-8 does not have Input 2 terminal connections or Input 2 trimpot.
6. To force the 120P to maximum gain (20 dB) for gain setup, connect a 1 V to 15 V power supply as shown, between terminal 10 or 11 and any 'S' terminal.
- 7 Speakers are connected to terminals 1 and 2.



SOLDER SIDE			COMPONENT SIDE		
PIN ¹	TRM ²	FUNCTION	PIN ¹	TRM ²	FUNCTION
1.		+15 VDC Regulated	2.		+15 VDC Regulated
3.		Expansion Input	4.		Expansion Output
5.		Output Trimpot Counterclockwise End	6.		Output Trimpot Wiper
7.		Output Trimpot Clockwise End ⁴	8.		Ground ³
9.	1	Output +	10.	2	Output –
11.		Input 1 Trimpot Counterclockwise End	12.		Input 1 Trimpot Wiper
13.		Input 1 Trimpot Clockwise End	14.		Ground ³
15.	4	Input 1 +	16.	5	Input 1 –
17.		Ground ³	18.		Ground ³
19.		Input 2 Trimpot Counterclockwise End ⁵	20.		Input 2 Trimpot Wiper ⁵
21.		Input 2 Trimpot Clockwise End ⁵	22.		Ground ³
23.	7	Input 2 + ⁵	24.	8	Input 2 – ⁵
25.		Ground ³	26.		Ground ³
27.		Not used	28.		Not used
29.		Not used	30.		Ground ³
31.	10	Not used	32.	11	Not used
33.		Ground ³	34.		Ground ³
35.		Not used	36.		Not used
37.		Not used	38.		Ground ³
39.	13	Input 1 Switch Control	40.	14	Input 2 Switch Control ⁵
41.		Phantom Powering Voltage +15 VDC or +48 VDC, Maximum	42.		Phantom Powering Voltage +15 VDC or +48 VDC, Maximum
43.		–15 VDC Regulated	44.		–15 VDC Regulated
NOTE 1 - PIN = Card edge connector terminal NOTE 2 - TRM = Rear panel screw terminal NOTE 3 - All ground connections are common on the card and on the 5032 motherboard ground plane. NOTE 4 - Connected to ground on this card. NOTE 5 - Not used with 5101PS, 5151PS, 5101PS-8					
Table 1 - Card Edge Connector Pin Assignments					

*Innovative Electronic Designs, Inc. • 9701 Taylorsville Road • Louisville, Kentucky 40299 • USA
Phone: (502) 267-7436 • Fax: (502) 267-9070 • Internet: <http://www.iedaudio.com>*