

**5201C, 5201C-8, 5251C,
5101C, 5101C-8, 5151C**

TWO INPUT, ONE OUTPUT MIXER CARDS WITH COMPRESSOR

DESCRIPTION

The 5201C subgroup of the 5000 Series Audio Processing System consists of six cards as described in Table 1 below. Each card has one or two balanced inputs mixed to one output. In the case of expansion cards (model numbers having an "E" suffix), which are used for adding extra inputs, the output is not available externally. It is routed, via the mother board, to the expansion input of the card located in the next slot to the right (as seen from the front) in the 5032 Mainframe.

MODEL	NUMBER OF INPUTS	INPUT LEVEL	NUMBER OF OUTPUTS	OUTPUT LEVEL
5201C	2	Line	1	Line
5201C-8	2	Line		Speaker
5251C	2	Microphone	1	Line
5101C	1	Line	1	Line
5101C-8	1	Line	1	Speaker
5151C	1	Microphone	1	Line

Table 1 - Model Descriptions

Cards having line level inputs use Model 100L Active Input Modules for input signal processing. Cards having microphone level inputs use Model 150M Active Input Modules for input signal processing. All cards with a '-8' suffix use Model 208S 8 Watt Power Amplifier Module in the output and have the capability of delivering 8 W to an 8 Ω speaker load. All other cards except expansion cards ('E' suffix) use Model 200L Active Output Modules, with balanced floating outputs, as drivers for the external loads.

Each input includes a Model 110C Compressor for reducing average level excursions.



SPECIFICATIONS

ELECTRICAL

1. Maximum Gain	
5201C, 5101C	44 dB
5201C-8, 5101C-8	54 dB
5251C, 5151C	77 dB
2. Input Gain Range	
5201C, 5201C-8, 5101C, 5101C-8	-2 dB - +18 dB
5251C, 5151C	+26 dB - +51 dB
3. Maximum Input Level	
At Minimum Input Gain	
5201C, 5201C-8, 5101C, 5101C-8	+22 dBu
5251C, 5151C	-5 dBu
At Maximum Input Gain	
5201C, 5201C-8, 5101C, 5101C-8	+2 dBu
5251C, 5151C	-31 dBu
4. Input Impedance (20 Hz - 20 kHz, Balanced)	
5201C, 5201C-8, 5101C, 5101C-8	10 M Ω in parallel with 1000 pF
5251C, 5151C	12 k Ω , \pm 5%
5. Maximum Output Attenuation	>90 dB
6. Maximum Output Level,	
5201C, 5101C, 5251C, 5151C	+10 dBu, min
$R_L \geq 600 \Omega$	
5201C-8, 5101C-8	+8 VRMS, min
$R_L \geq 8 \Omega$	
7. Output Impedance	
5201C, 5101C, 5251C, 5151C	<0.5 Ω
20 Hz - 20 kHz, Balanced and Floating	
5201C-8, 5101C-8	<0.5 Ω
20 Hz - 20 kHz	
8. Frequency Response	\pm 0.5 dB
20 Hz - 20 kHz	
9. Total Harmonic Distortion, THD	
5201C, 5101C, 5251C, 5151C	<.02%
2 kHz - 20 kHz, +24 dBu	
5201C-8, 5101C-8	<.3%
2 kHz - 20 kHz, 8 W, $R_L=8\Omega$	
10. Intermodulation Distortion, IMD	
5201C, 5101C, 5251C, 5151C	<0.1%
60 hZ/7 KhZ, +24 dBu	
5201C-8, 5101C-8	< 2%
60 hZ/7 KhZ, 8 W, $R_L=8\Omega$	

Innovative Electronic Designs, Inc. • 9701 Taylorsville Road • Louisville, Kentucky 40299 • USA
Phone: (502) 267-7436 • Fax: (502) 267-9070 • Internet: <http://www.iedaudio.com>

11. Signal-to Noise Ratio, S/N	
5201C, 5101C	>60 dB
26 dB Gain, referred to +4 dBu, 22 Hz - 22 kHz filters	
5201C-8, 5101C-8.	>60 dB
below 1 W reference, 16 dB gain, 22 Hz - 22 kHz filters	
5251C, 5151C.	>60 dB
Gain = 52 dB, referred to +2 dBu, 22 Hz - 22 kHz filters	
12. Common Mode Rejection Ratio, CMRR	
5201C, 5201C-8, 5101C, 5101C-8	>60 dB
20 Hz - 20 kHz	
5251C, 5151C.	>80 dB
20 Hz - 20 kHz	
13. Compressor Characteristics	
Compression Threshold, Input Gain Set to Minimum	
5201C, 5201C-8, 5101C, 5101C-8	-20.5 dB
5251C, 5151C	-48.5 dB
Compression Threshold, Input Gain Set to Maximum	
5201C, 5201C-8, 5101C, 5101C-8	-40.5 dB
5251C, 5151C	-73.5 dB
Compression Ratio.	6:1
Attack Time, 10 dB input step.	5 mSec
Release Time	
40 dB input drop.	15 Sec
10 dB input drop	3 Sec
14. Power Requirements	
Supply Voltage	±15 V
Typical Current Drain	
5201C	71 mA
5201C-8	
Quiescent	73 mA
8 W, $R_L=8\ \Omega$	500 mA
5251C	75 mA
5251C-8	
Quiescent	77 mA
8 W, $R_L=8\ \Omega$	500 mA
5101C.	51 Ma
5101C-8	
Quiescent	53 mA
8 W, $R_L=8\ \Omega$	500 mA
5151C	53 mA
5151C-8	
Quiescent	55 mA
8 W, $R_L=8\ \Omega$	500 mA
15. DC Voltage Short Circuit Protection	
5201C, 5251C, 5101C, 5151C	Thermistor (Self Resetting)
5201C-8, 5101C-8	1.5 A Pico Fuse

MECHANICAL

1. Size (maximum Overall Dimensions)

Height	2.8"
Width	1.25"
Depth	8.4"

2. Weight

5201C72lb
5201C-868lb
5251C71lb
5101C48lb
5101C-845lb
5151C47lb

ENVIRONMENTAL

1. Operating Temperature Range (+32°F - +131°F) 0°C - +55°C

2. Storage Temperature Range (-40°F - +158°F) -40°C - +70°C

Innovative Electronic Designs, Inc. • 9701 Taylorsville Road • Louisville, Kentucky 40299 • USA
Phone: (502) 267-7436 • Fax: (502) 267-9070 • Internet: <http://www.iedaudio.com>

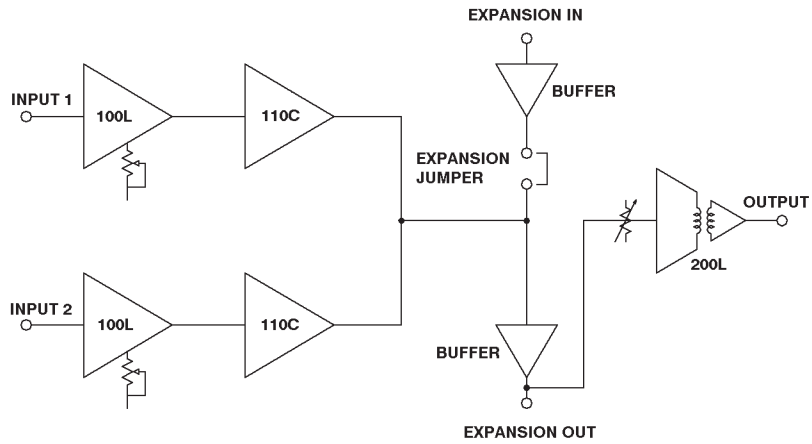

Figure 1 - 5201C Block Diagram

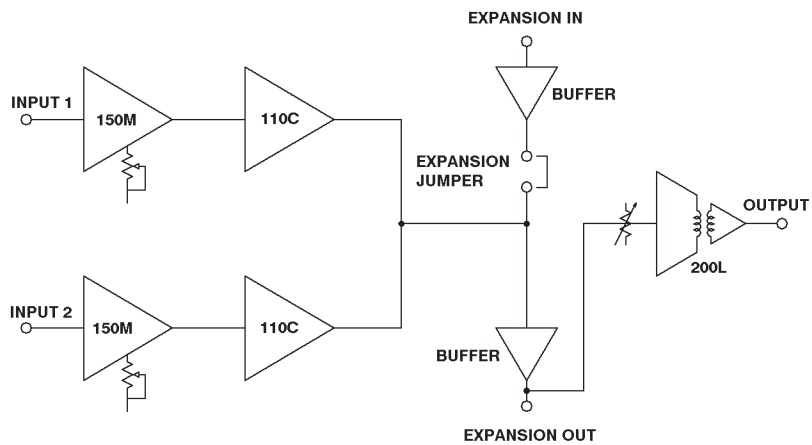

Figure 2 - 5251C Block Diagram



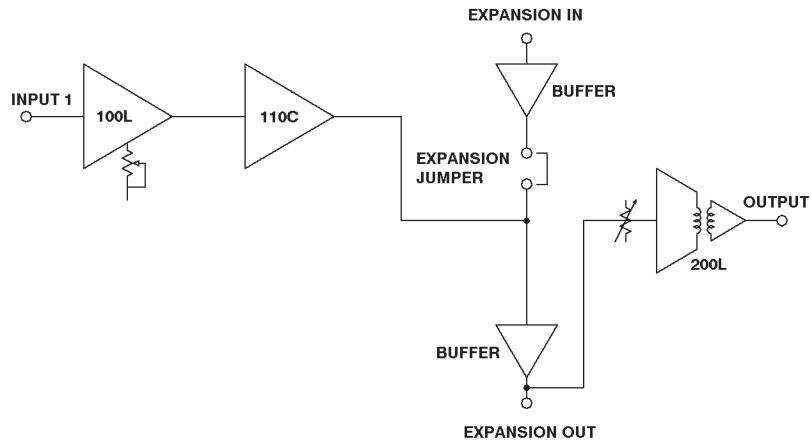

Figure 3 - 5101C Block Diagram

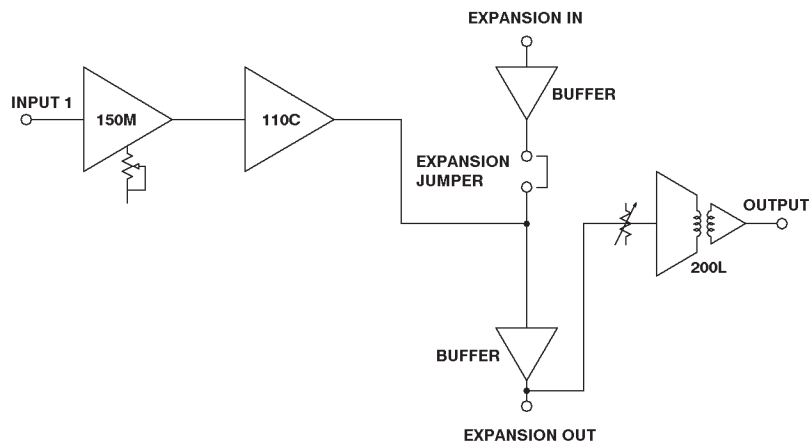

Figure 4 - 5151C Block Diagram

*Innovative Electronic Designs, Inc. • 9701 Taylorsville Road • Louisville, Kentucky 40299 • USA
 Phone: (502) 267-7436 • Fax: (502) 267-9070 • Internet: <http://www.iedaudio.com>*

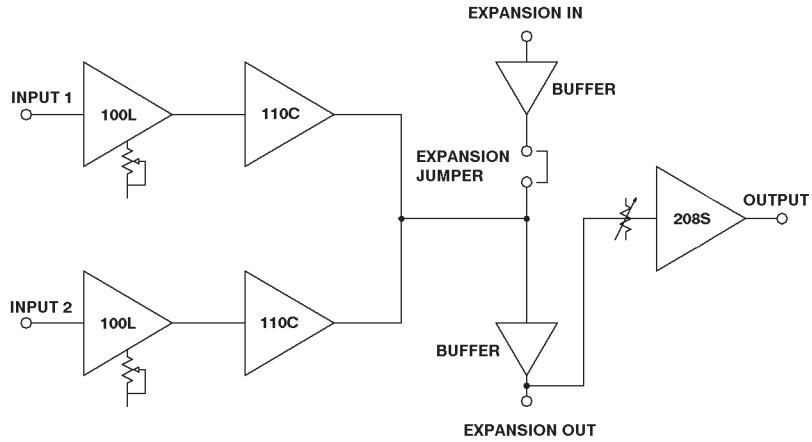

Figure 5 - 5201C-8 Block Diagram

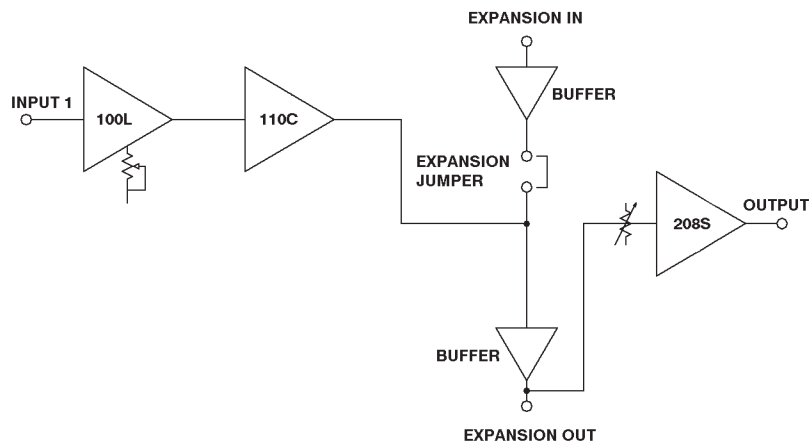

Figure 6 - 5101C-8 Block Diagram



This page left blank intentionally

*Innovative Electronic Designs, Inc. • 9701 Taylorsville Road • Louisville, Kentucky 40299 • USA
Phone: (502) 267-7436 • Fax: (502) 267-9070 • Internet: <http://www.iedaudio.com>*