

MODEL 4452 AUTOMATIC MIXER

INSTALLATION INSTRUCTIONS

Table of Contents

Setup Jumpers and Controls - 4452	1
Setup Jumpers and Controls - 4452E	2
Setup Jumpers and Controls - 4452C	3
Setup Jumpers and Controls - 4452CE	4
Card Linking Using Jumpers - 4452 and 4452E Only	5
Phantom Power Setup	8
Gain Adjustment of Gated Inputs	9
Input Option Control Lines	10
Auxiliary Mix Bus Sources	11
Direct Output Source Selection	12
Main and Auxiliary Mix Bus Level Controls	13
Release Time Adjustment of Gated Inputs	14
Main and Auxiliary Output Level Adjustment	15
Force On or Force Off of Gated Inputs	16
Enabling/Disabling Priority of Gated Inputs	17
Filibuster Limit Set of Gated Inputs	18
Onput Option for Gated Inputs	19
Output Option Control Selection	20
Digital Attenuator Defeat for Gated Inputs	21
Discriminator Defeat for Gated Inputs	22
Discriminator Sensitivity and Offset Adjustment for Gated Inputs	23
Model 4174 Mainframe Rear Terminal Identification	24
Typical Gated Input Connections	25
Typical Direct Input Connections	26
Main and Auxliary Output Connections to Balanced Loads	27
Main and Auxliary Output Connections to Unbalanced Loads	28
Typical Direct Output Connections	29
Using the 112PLC to Control the Levels of Inputs and Outputs Which Have the Model 132 VCDA	30
Using Rotary Pots to Control the Levels of Inputs and Outputs Which Have the Model 132 VCDA	31
Controlling Input and Output Levels With the Model 110V VCA	32
Remote Channel On Indicators Using The Logic Outputs	33
Remote Manual Control of Force On/Off Using the Logic Outputs	34
Remote Manual Control of Force On/Off Using the Direct Inputs	35



This page left blank intentionally

*Innovative Electronic Designs, Inc. • 9701 Taylorsville Road • Louisville, Kentucky 40299 • USA
Phone: (502) 267-7436 • Fax: (502) 267-9070 • Internet: <http://www.iedaudio.com>*

SETUP JUMPERS AND CONTROLS - 4452

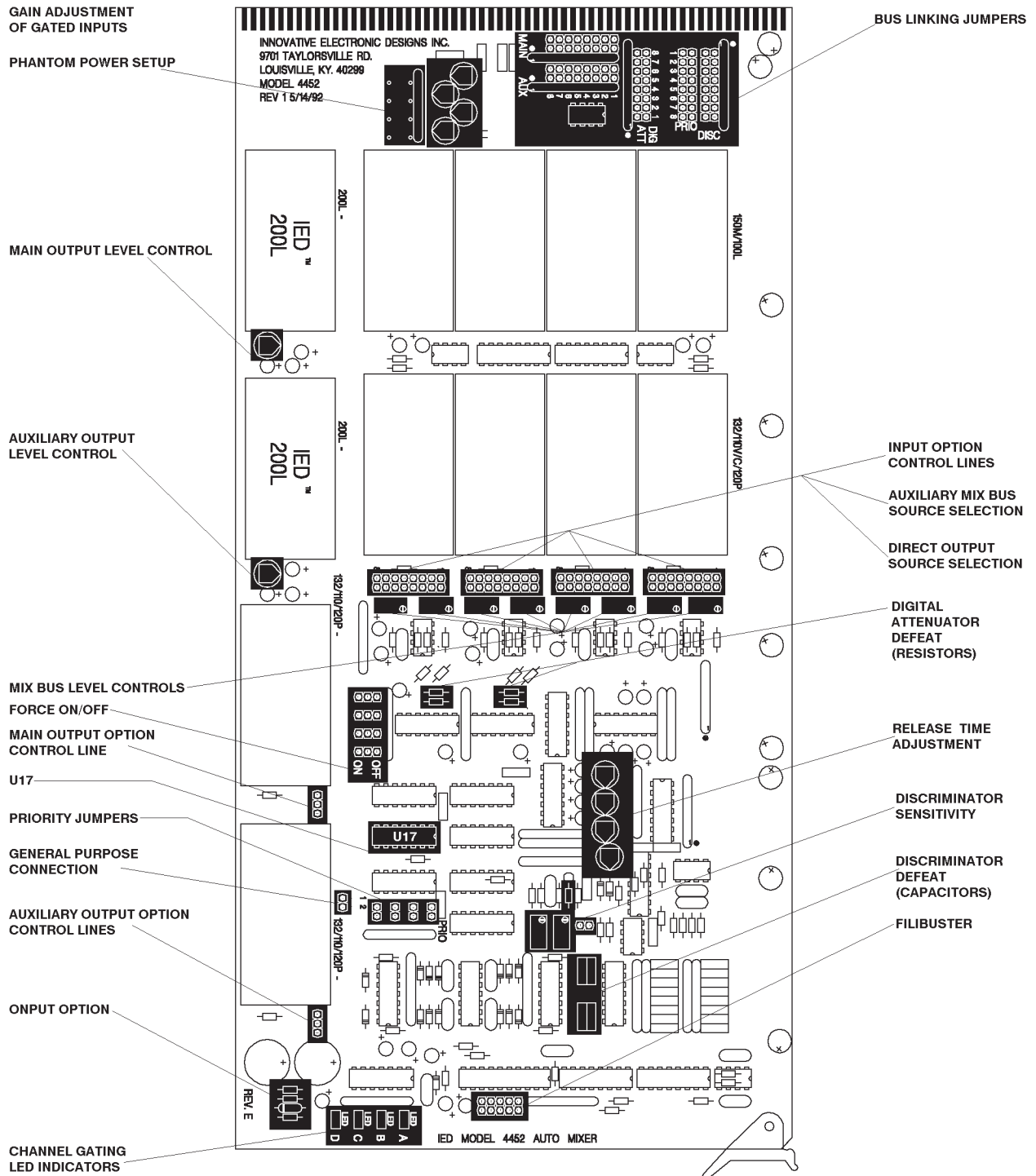

Figure 1 - Location of setup jumpers and controls
4452



SETUP JUMPERS AND CONTROLS - 4452E

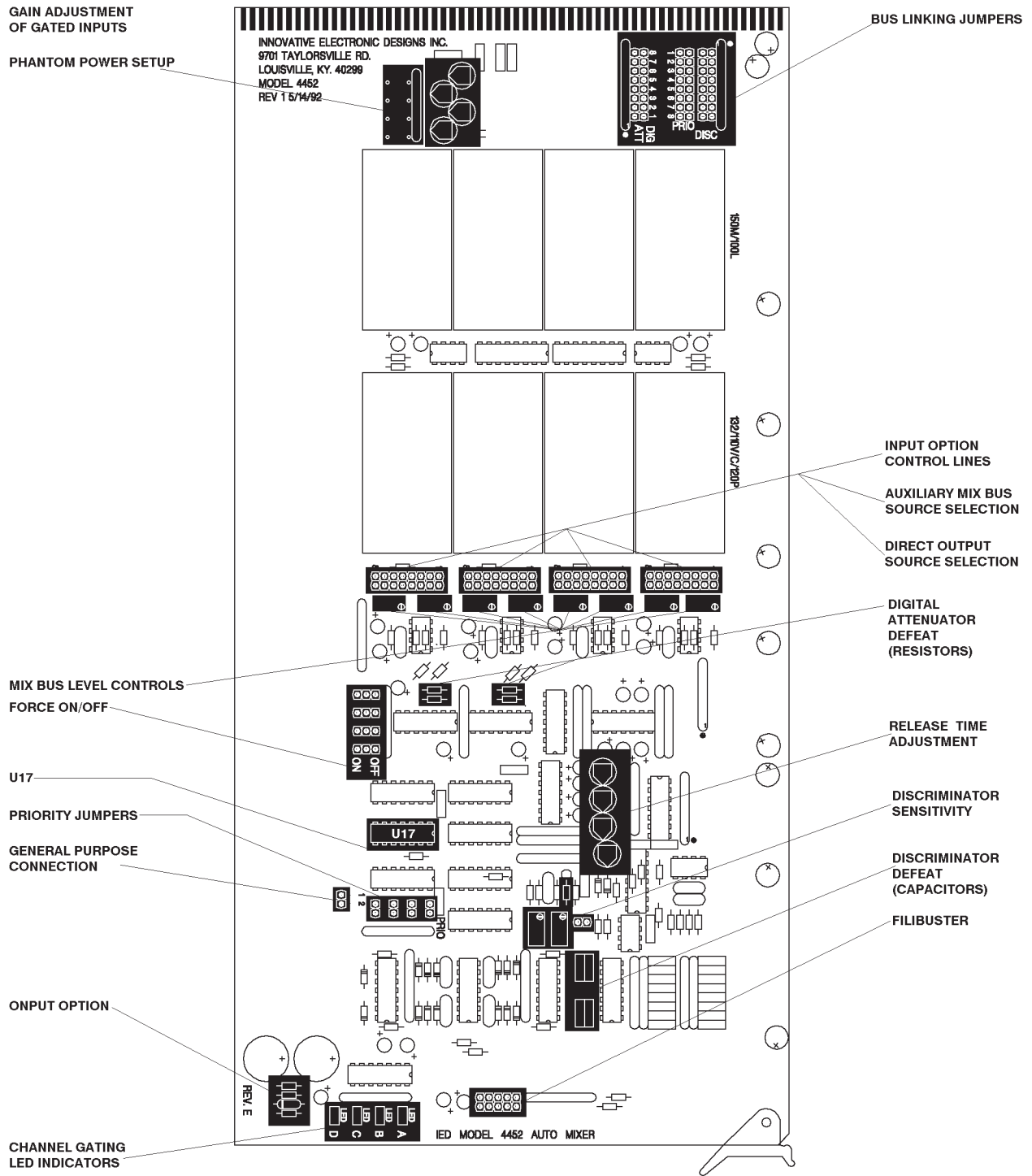

Figure 2 Location of setup jumpers and controls
4452E

*Innovative Electronic Designs, Inc. • 9701 Taylorsville Road • Louisville, Kentucky 40299 • USA
Phone: (502) 267-7436 • Fax: (502) 267-9070 • Internet: <http://www.iedaudio.com>*

SETUP JUMPERS AND CONTROLS - 4452C

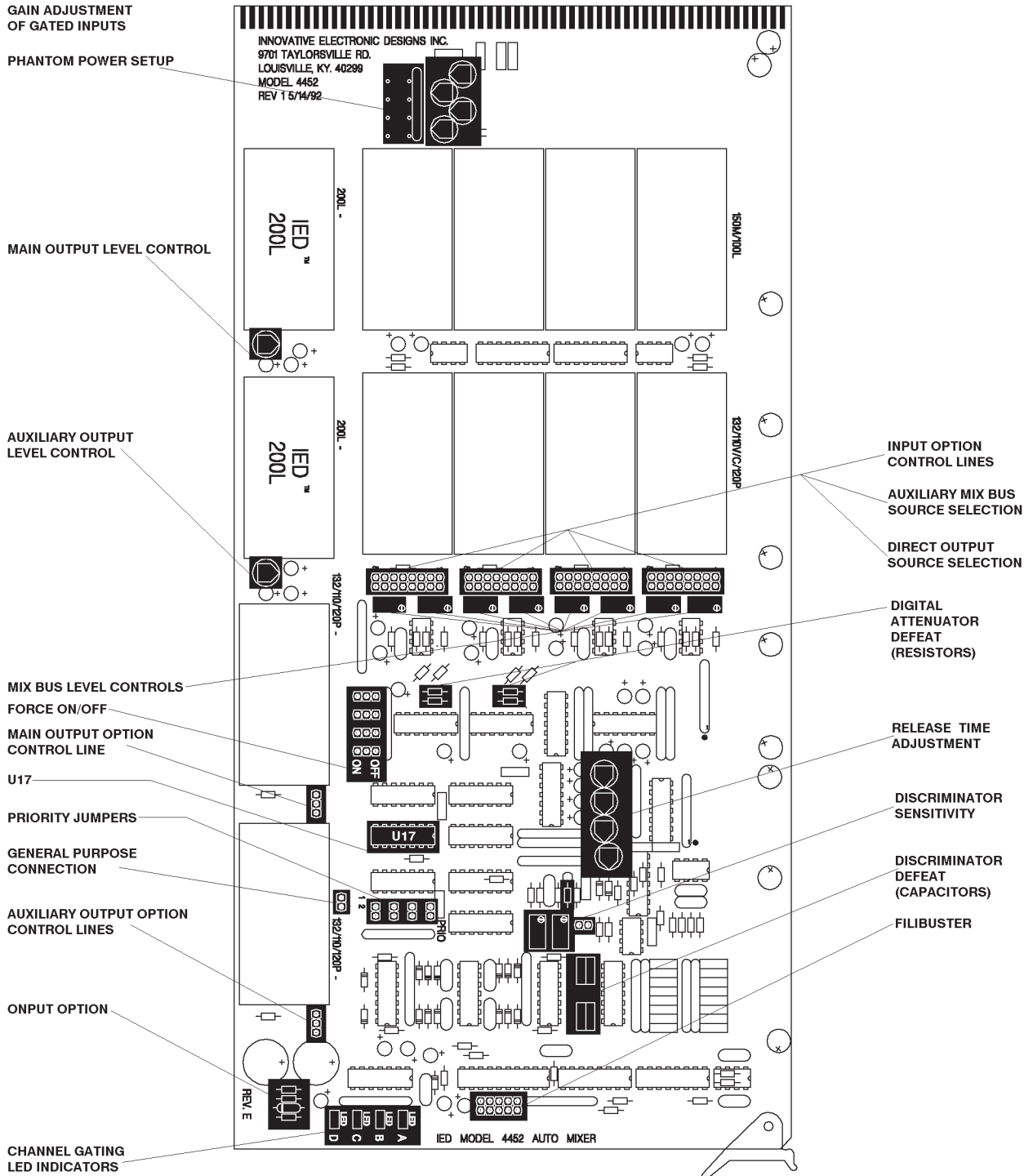

Figure 3 - Location of setup jumpers and controls
4452C



SETUP JUMPERS AND CONTROLS - 4452CE

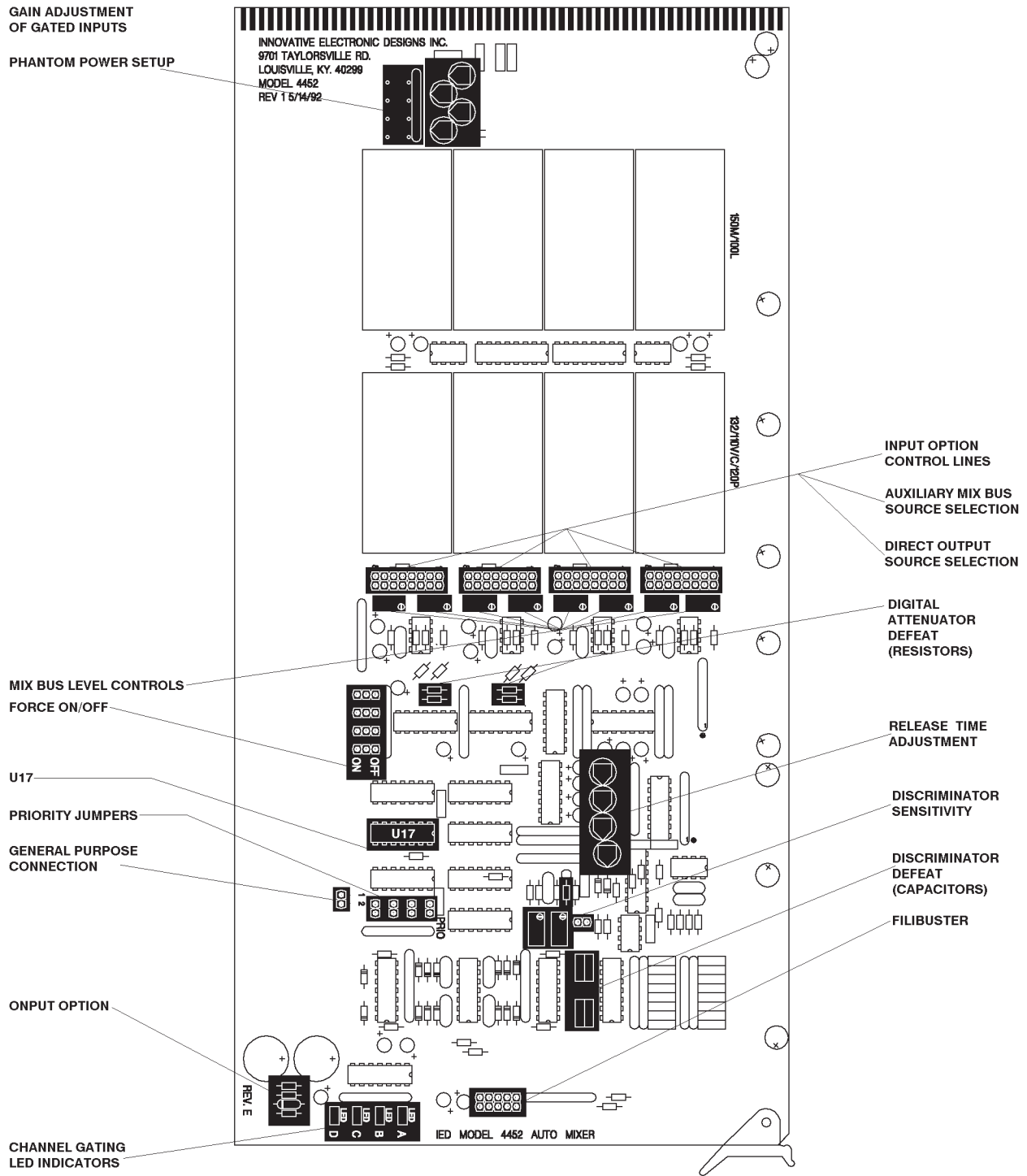
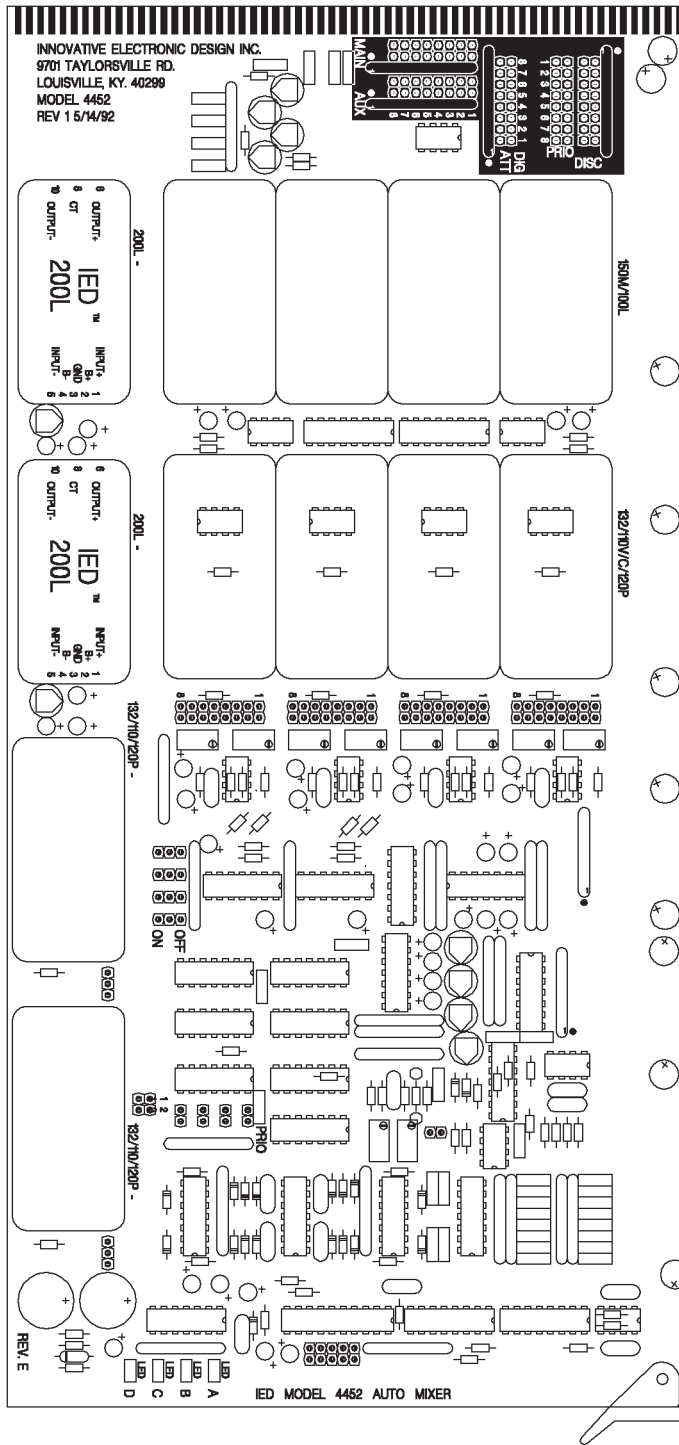

Figure 4 - Location of setup jumpers and controls
4452CE

*Innovative Electronic Designs, Inc. • 9701 Taylorsville Road • Louisville, Kentucky 40299 • USA
 Phone: (502) 267-7436 • Fax: (502) 267-9070 • Internet: <http://www.iedaudio.com>*

CARD LINKING USING JUMPERS - 4452 AND 4452E ONLY



The 4000 series automatic mixer accomplishes card-to-card linking by sharing certain information between cards. This information can be fully or partially accessed, dependent on need, by installing linking jumpers. Refer to figure 5 for the location of the linking jumpers on the 4452 card. The information which can be shared between cards is referred to as the 5 Linking Options. These options consist of the following:

- 1) Discriminator information
- 2) Priority information
- 3) Digital Attenuator information
- 4) Main audio
- 5) Auxiliary audio

Each mixer card in the Model 4452 Automatic Mixer Series has four gated inputs. In order to produce mixers with a greater number of gated inputs (up to 32 gated inputs in each main-frame), the mixer cards must be linked. Linking allows the cards to perform as a single larger mixer in every respect.

This example makes use of 4452 cards with Main and Aux outputs. In most systems, a card group such as that shown in figure would have only one 4452 card. It would be designated as the main card, and would be placed in the furthest right position of the group. The remainder of the cards in the group would be 4452E Expansion Cards. Expansion cards are more economical, since their Main and Aux Outputs, which are not used, are omitted, as are their corresponding bus jumpers.

To understand the 4000 Series linking operation we will select one of the 4452 Automatic Mixer card inserted in a 4174 mainframe. The shaded card in Figure 9 will be used as an example. When the 4452 automatic mixer card being discussed is mounted in the 4174 Mainframe, its 5 Linking Options are available to the other cards in the mainframe via the 4174 bus system. Installing a shunt in the #1 position, on each linking option as illustrated in Figure 10 allows the 4452 to completely link to itself. Focus-

Figure 5 - Location of linking jumpers on the 4452 card



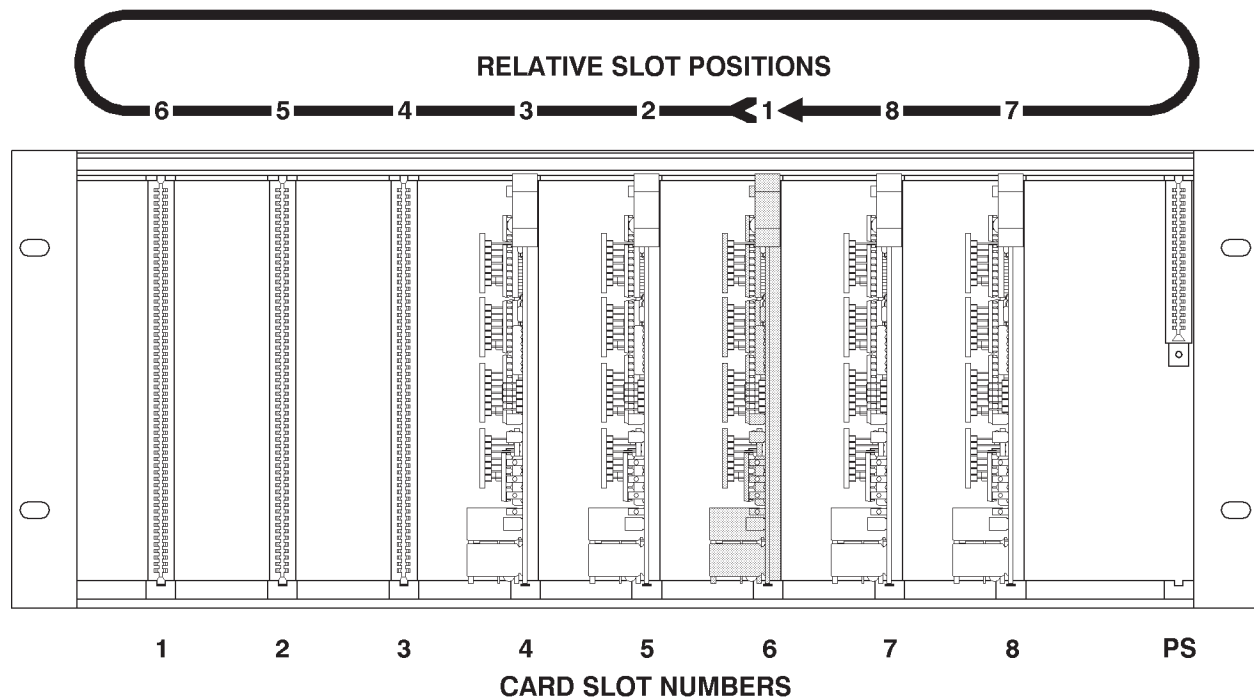

Figure 6 - Illustration of relative position numbering

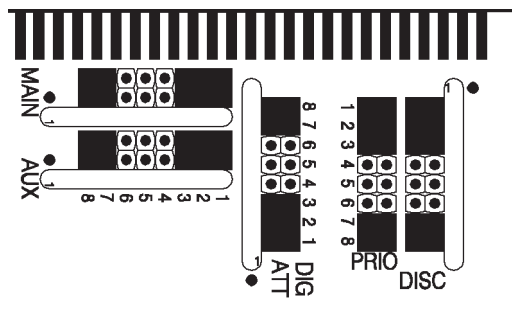

Figure 7 - Jumpering for the card in slot 6 in Figure 9 above

ing on the Main Audio for example, installing a jumper in the #1 position allows the mixed gated inputs to pass to its own Main output.

In referring back to figure 6, the shaded card can access, either partially or fully, the linking options of any or all of the remaining cards.

Figure 6 illustrates relative position numbering. In the example shown, the card in slot 6 is to be jumpered to link it with the cards in slots 4, 5, 7, and 8, as well as its own output. Each card, as it is being jumpered, is in relative position 1. Therefore, a jumper must be placed in position 1 on each of the five buses in order to link a card to its own buses. Normally, this is done as a matter of course, but under some

special circumstances it may be useful to omit a jumper. Jumpers must be placed on each of the five buses for each of the other cards to be linked, using their relative slot positions. Since there are cards in relative positions 1, 2, 3, 7, and 8, for complete linking, there must be jumpers in positions 1, 2, 3, 7, and 8 on each of the five buses. Figure 7 illustrates the complete jumpering for the card in slot 6. Figure 8 illustrates the jumper placement for complete linking of all cards in the group.

*Innovative Electronic Designs, Inc. • 9701 Taylorsville Road • Louisville, Kentucky 40299 • USA
Phone: (502) 267-7436 • Fax: (502) 267-9070 • Internet: <http://www.iedaudio.com>*

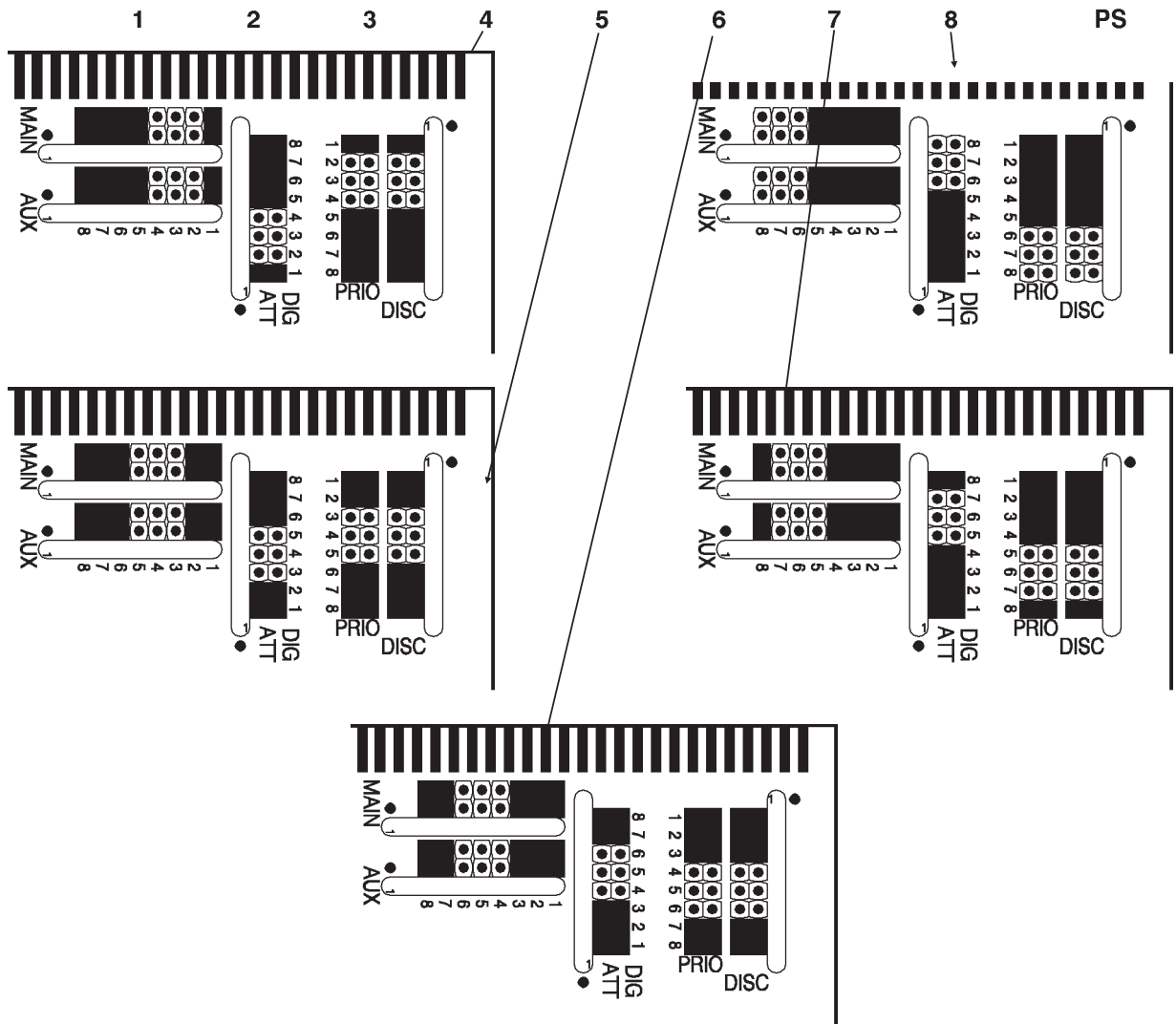
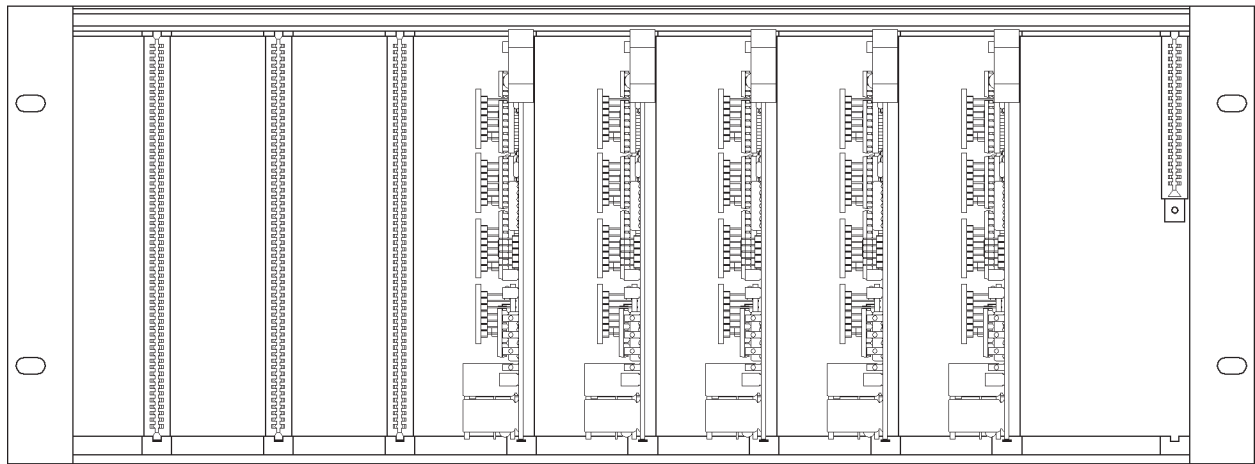
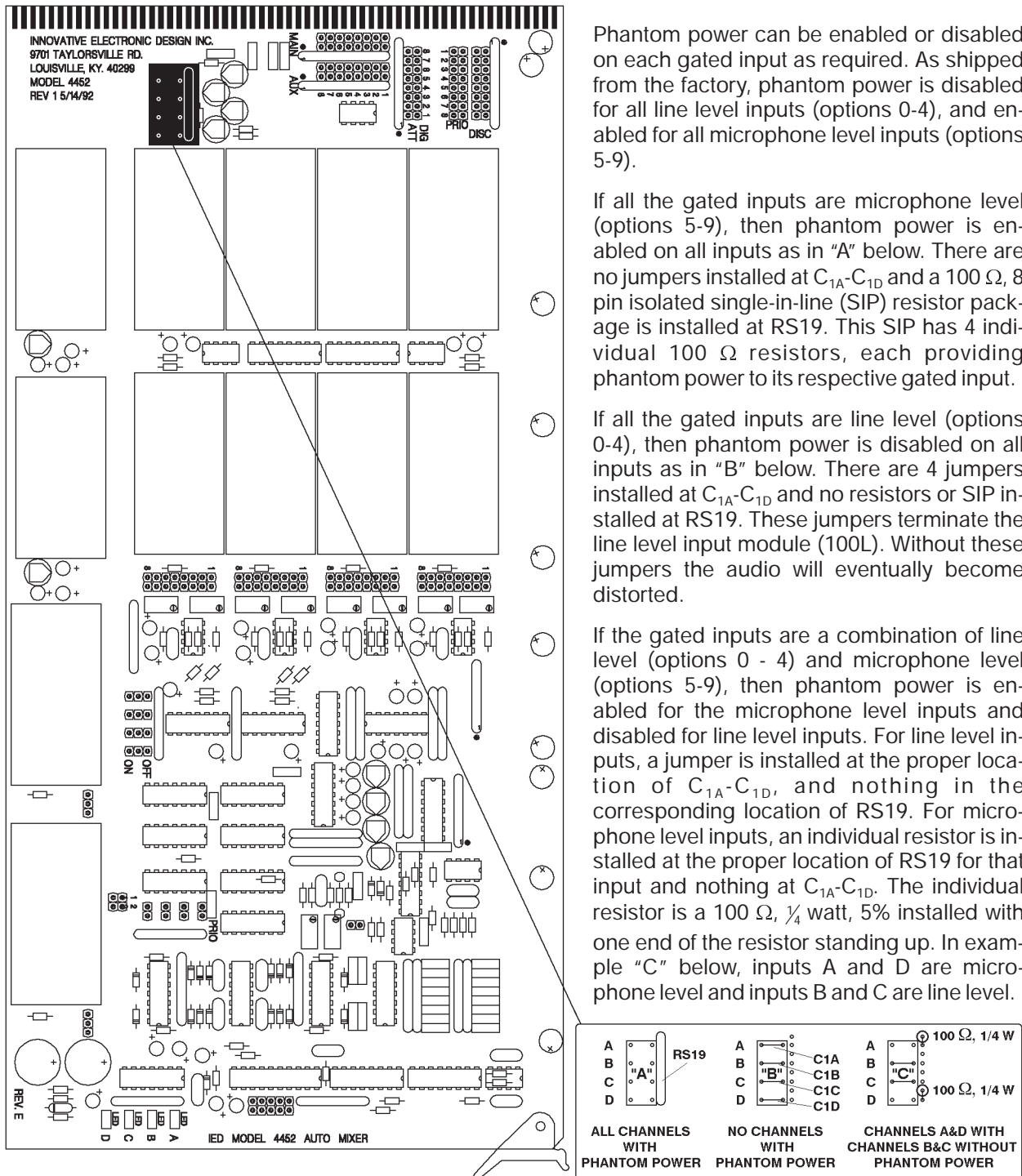

Figure 8 - Jumper placement for all cards in the group



PHANTOM POWER SETUP



Phantom power can be enabled or disabled on each gated input as required. As shipped from the factory, phantom power is disabled for all line level inputs (options 0-4), and enabled for all microphone level inputs (options 5-9).

If all the gated inputs are microphone level (options 5-9), then phantom power is enabled on all inputs as in "A" below. There are no jumpers installed at C_{1A}-C_{1D} and a 100 Ω, 8 pin isolated single-in-line (SIP) resistor package is installed at RS19. This SIP has 4 individual 100 Ω resistors, each providing phantom power to its respective gated input.

If all the gated inputs are line level (options 0-4), then phantom power is disabled on all inputs as in "B" below. There are 4 jumpers installed at C_{1A}-C_{1D} and no resistors or SIP installed at RS19. These jumpers terminate the line level input module (100L). Without these jumpers the audio will eventually become distorted.

If the gated inputs are a combination of line level (options 0 - 4) and microphone level (options 5-9), then phantom power is enabled for the microphone level inputs and disabled for line level inputs. For line level inputs, a jumper is installed at the proper location of C_{1A}-C_{1D}, and nothing in the corresponding location of RS19. For microphone level inputs, an individual resistor is installed at the proper location of RS19 for that input and nothing at C_{1A}-C_{1D}. The individual resistor is a 100 Ω, ¼ watt, 5% installed with one end of the resistor standing up. In example "C" below, inputs A and D are microphone level and inputs B and C are line level.

Figure 9 - Enabling phantom power

*Innovative Electronic Designs, Inc. • 9701 Taylorsville Road • Louisville, Kentucky 40299 • USA
Phone: (502) 267-7436 • Fax: (502) 267-9070 • Internet: <http://www.iedaudio.com>*

GAIN ADJUSTMENT OF GATED INPUTS

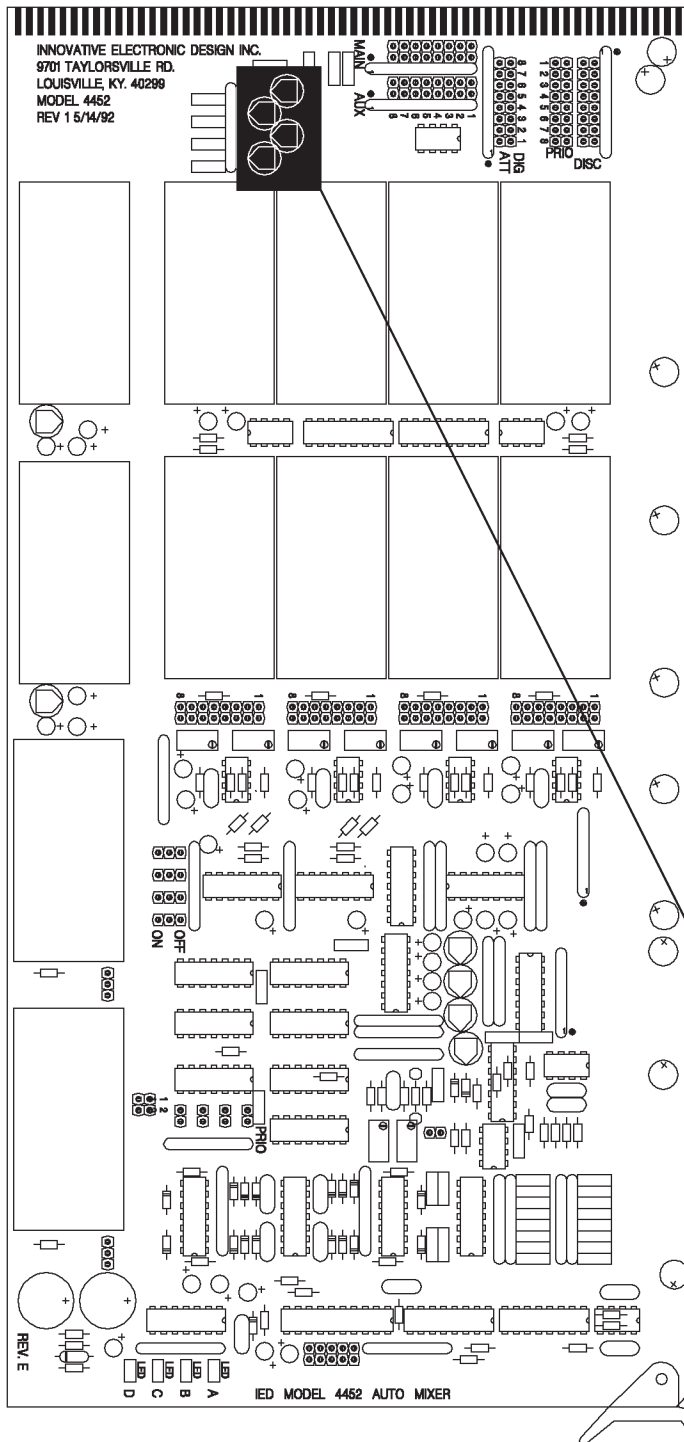

Gated Inputs - For line level options (input options 0 - 4) the gain range of the gated inputs is -2 dB to +18 dB. For these options the gain is factory preset at minimum (-2 dB).

For the microphone level options input (options 5 - 9) the gain range of gated inputs is +26 dB to +46 dB. It factory preset at approximately 35 dB.

To change the gain, rotate the pot for the desired input, clockwise to increase or counter-clockwise to decrease. See the figure at the left and the detail below.

For input options which make use of the Model 120P, its gain must be forced to maximum before adjusting the input gain. This is accomplished by placing a jumper on Control 1 for the appropriate input. See figure 8, page 7. After making the desired adjustment, remove the jumper.

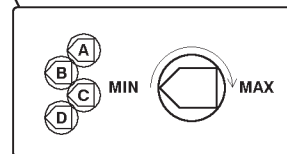
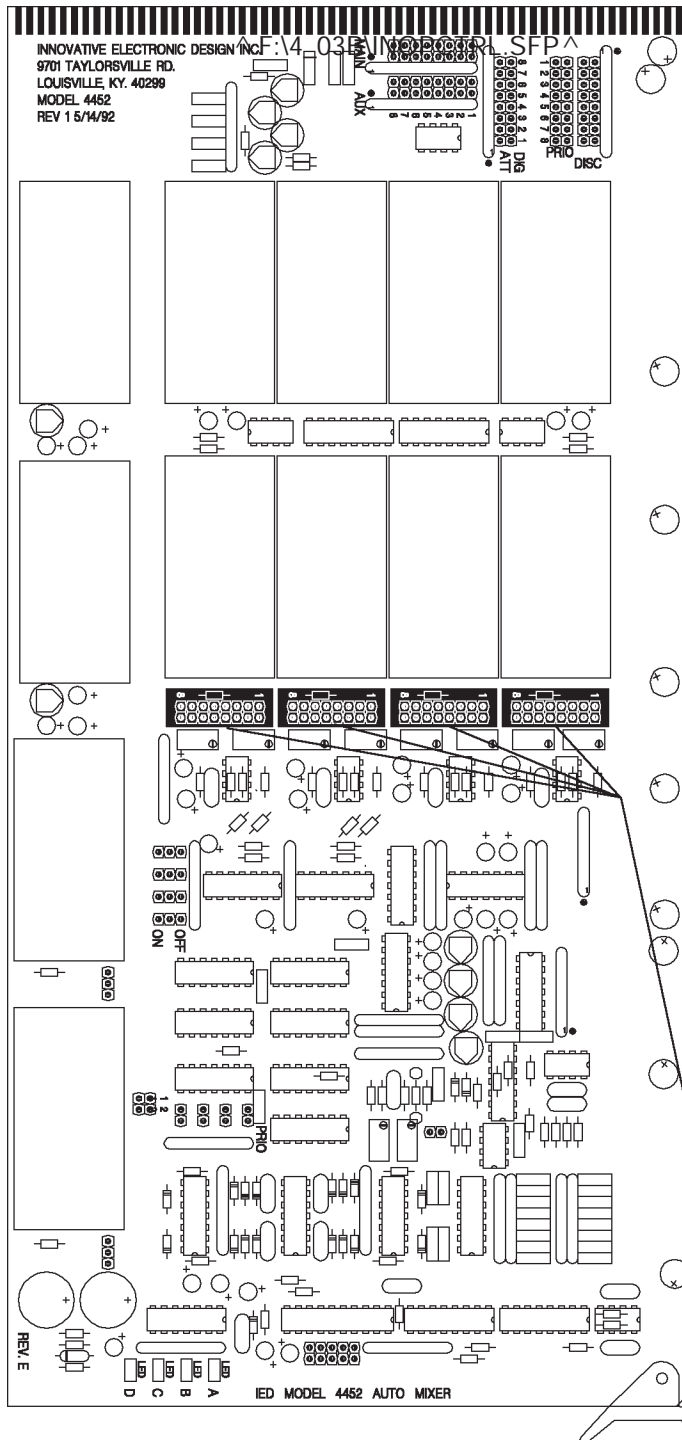

Figure 10 - Gain adjustment of gated inputs



INPUT OPTION CONTROL LINES



The Input Option Control Lines are factory set according to the input option selected and should not be changed. Refer to the figure below for details of jumper setup.

The table below shows which control line must have a jumper in place for each input option.

OPTION NUMBER	INPUT MODULE	CONTROL LINE
0	None	None
1	110V	2
2	120P	None
3	132	1
4	110C	None
5	None	None
6	110V	2
7	120P	None
8	132	1
9	110C	None

When setting or changing the gain of a channel which makes use of the 120P, options 2 and 7, a jumper must be placed temporarily to select control line 1 while the gain is being adjusted. This forces the 120P to maximum gain. The jumper is removed after completing the adjustment.

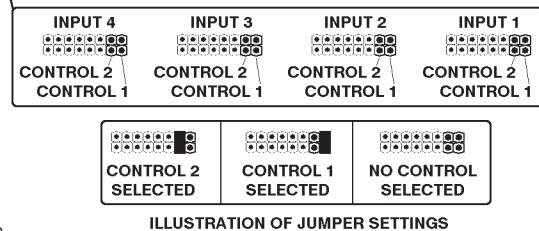
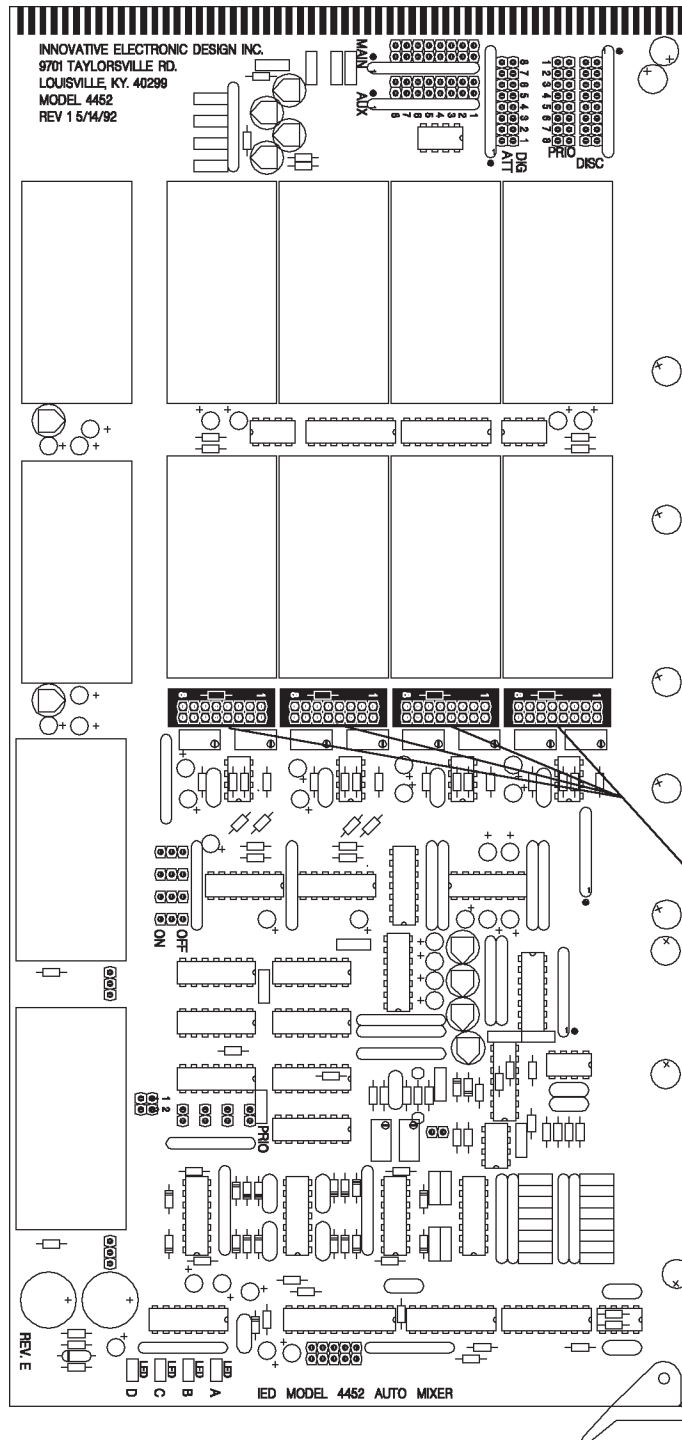

Figure 11 - Setting input option control jumpers

*Innovative Electronic Designs, Inc. • 9701 Taylorsville Road • Louisville, Kentucky 40299 • USA
 Phone: (502) 267-7436 • Fax: (502) 267-9070 • Internet: <http://www.iedaudio.com>*

AUXILIARY MIX BUS SOURCES



The Auxiliary Output mix can be sourced from one of three points for each gated input. The three points are Pre Input Option, Post Input Option, and Post Gate. The selection is made by the placement of jumpers. Refer to the figure below for the details of jumper setup. When shipped from the factory, there is a jumper in the Post Gate position for each input.

The Pre Option selection feeds the input signal prior to input processing to the Auxiliary Output mix bus. Input processing refers to the selected input option. The output level of the input module must be @0 dBu, or clipping will occur.

The Post Option selection feeds the input signal to the Auxiliary Output mix bus after it has received input processing, but before it is gated.

The Post Gate selection feeds the input signal to the Auxiliary Output mix bus after it has received input processing and after it passes through the gating switch. This is the same signal which is fed to the Main Output mix bus.

Never install jumpers in more than one position for the pre-option, post option, or post gate setup.

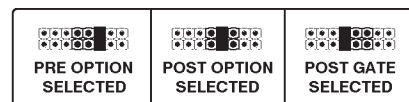
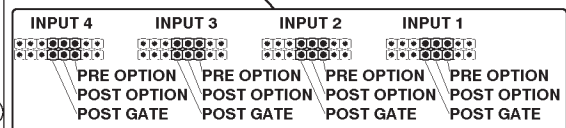
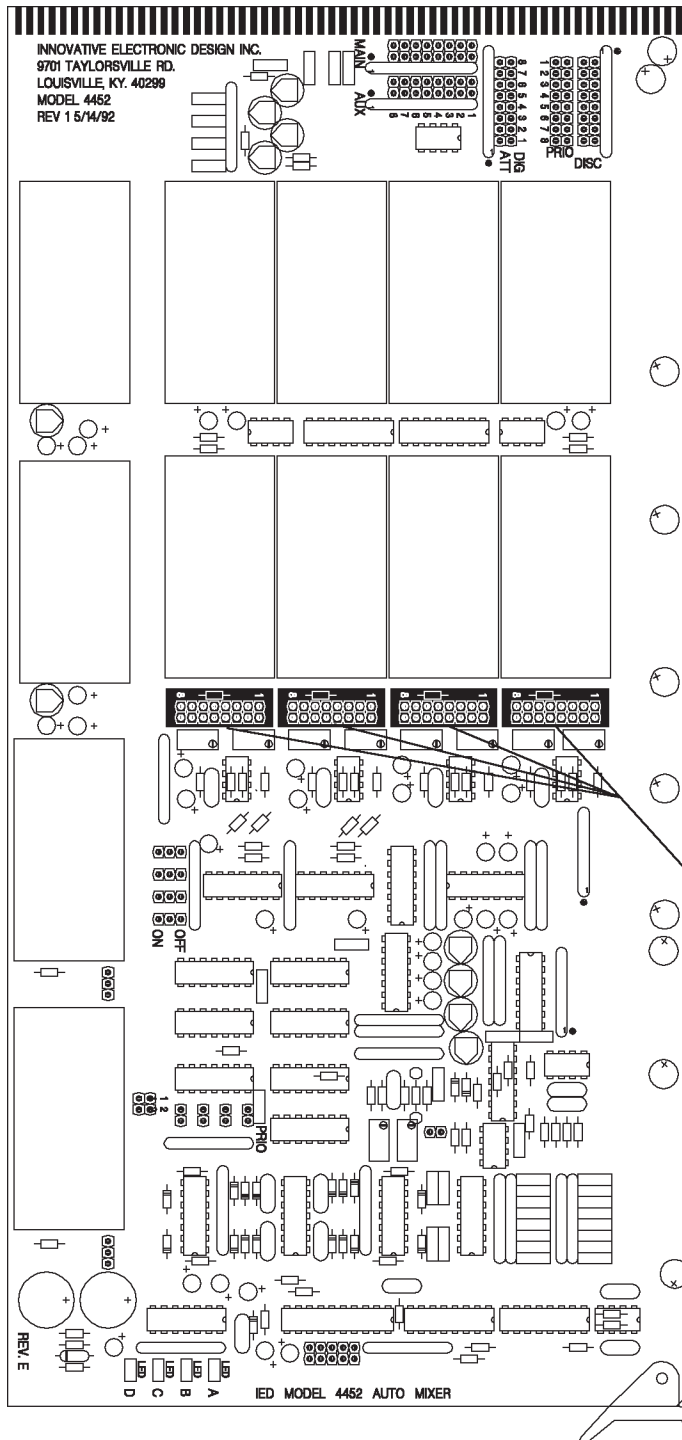

ILLUSTRATION OF JUMPER SETTINGS

Figure 12 - Selecting the Auxiliary mix bus source



DIRECT OUTPUT SOURCE SELECTION



The Direct Output can be sourced from the Aux mix bus feed, the Main mix bus feed, or it may be Off for each gated input. The selection is made by the placement of jumpers. Refer to the figure below for the details of jumper setup. When shipped from the factory, there is a jumper in the Main mix bus feed position for each input.

The Aux mix bus feed selection feeds the input signal to the Direct Output from the wiper of the Aux mix bus pot for that input. Prior processing depends on the placement of the Aux Source selection jumper.

The Off selection feeds no signal to the Direct Output by grounding the input to the Direct Output op amp.

The Main mix bus feed selection feeds the input signal to the Direct Output after it has received input processing and after it passes through the gating switch and the mix bus pot. This is the same signal which is fed to the Main Output mix bus.

Never install jumpers in more than one position for the Aux Source, Off, or post gate setup.

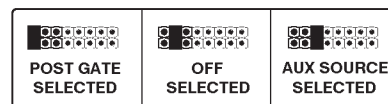
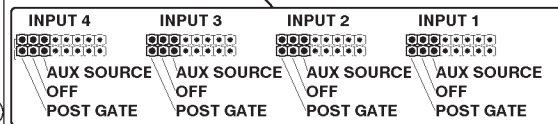
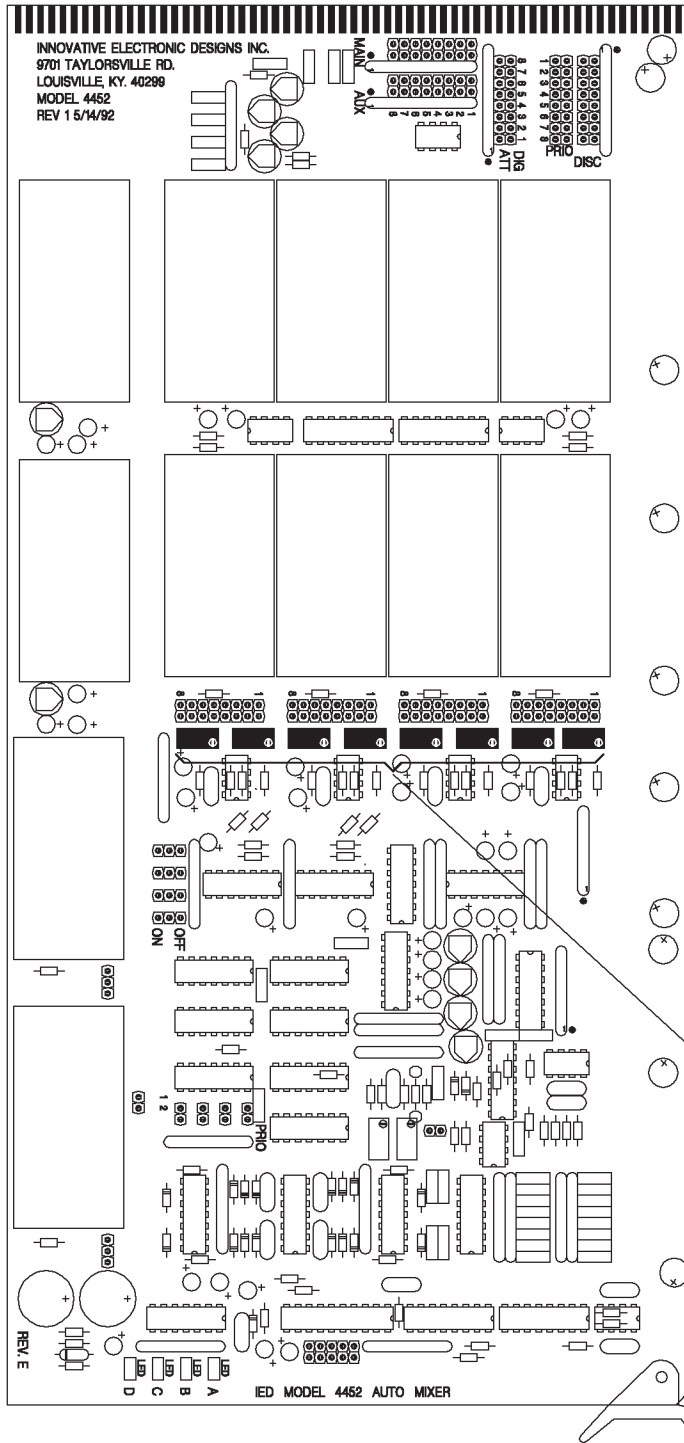

ILLUSTRATION OF JUMPER SETTINGS

Figure 13 - Selecting the Direct Output source

Innovative Electronic Designs, Inc. • 9701 Taylorsville Road • Louisville, Kentucky 40299 • USA
Phone: (502) 267-7436 • Fax: (502) 267-9070 • Internet: <http://www.iedaudio.com>

MAIN AND AUXILIARY MIX BUS LEVEL CONTROLS



The Main and Auxiliary Mix Bus level controls are multi-turn pots. There is one pot for each input on each bus, for a total of eight pots. See the detail below for the location of each pot.

Level is increased by clockwise rotation, or decreased by counterclockwise rotation. Levels can be adjusted over the range of no attenuation to -80 dB.

When shipped from the factory, the Main Mix bus is set at -14 dB, and the Aux mix bus is set at -10 dB.

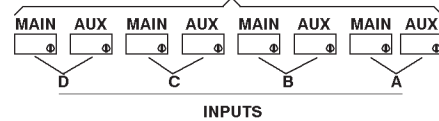

Figure 14 - Setting the Main and Auxiliary Mix Bus levels



RELEASE TIME ADJUSTMENT OF GATED INPUTS

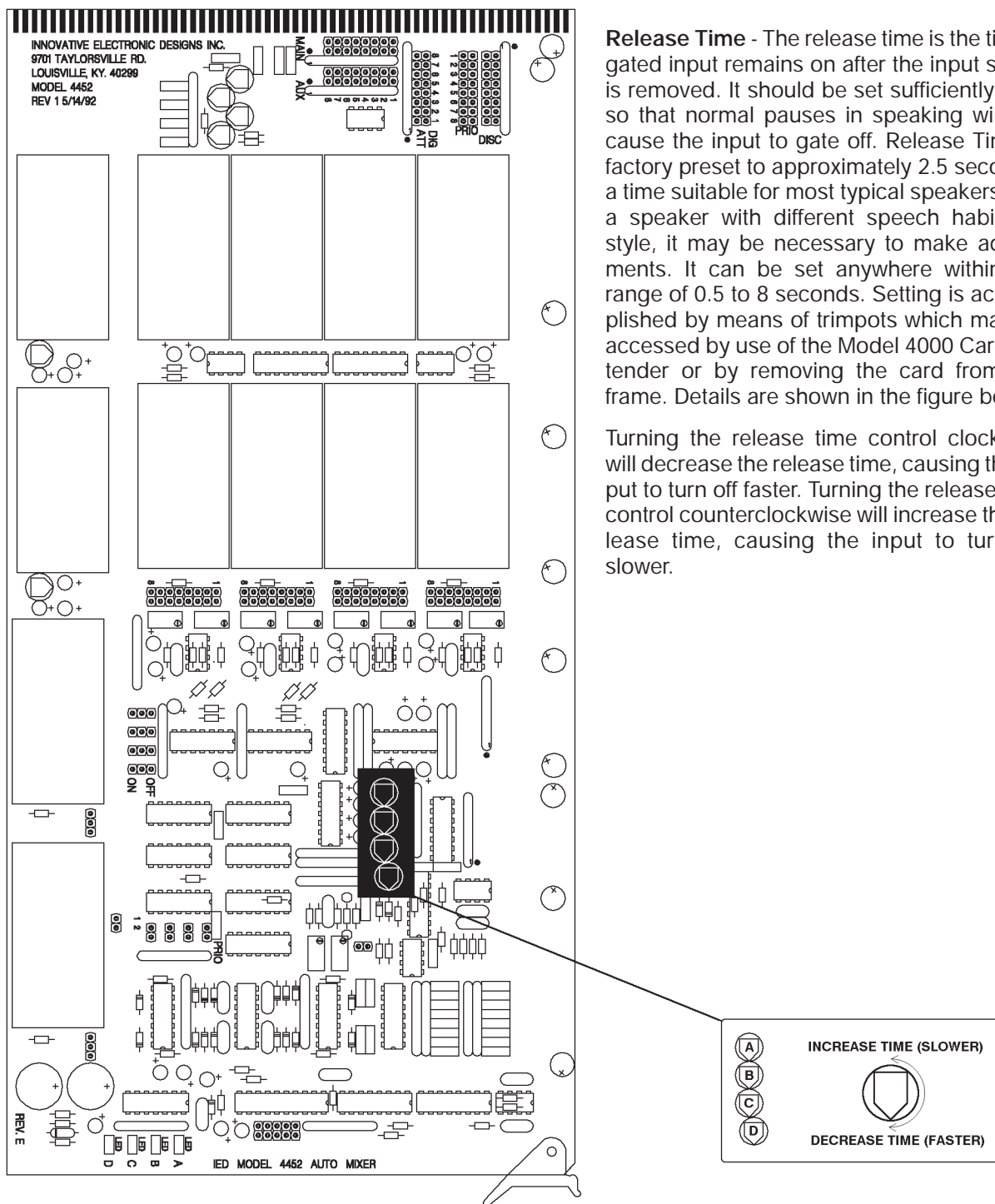
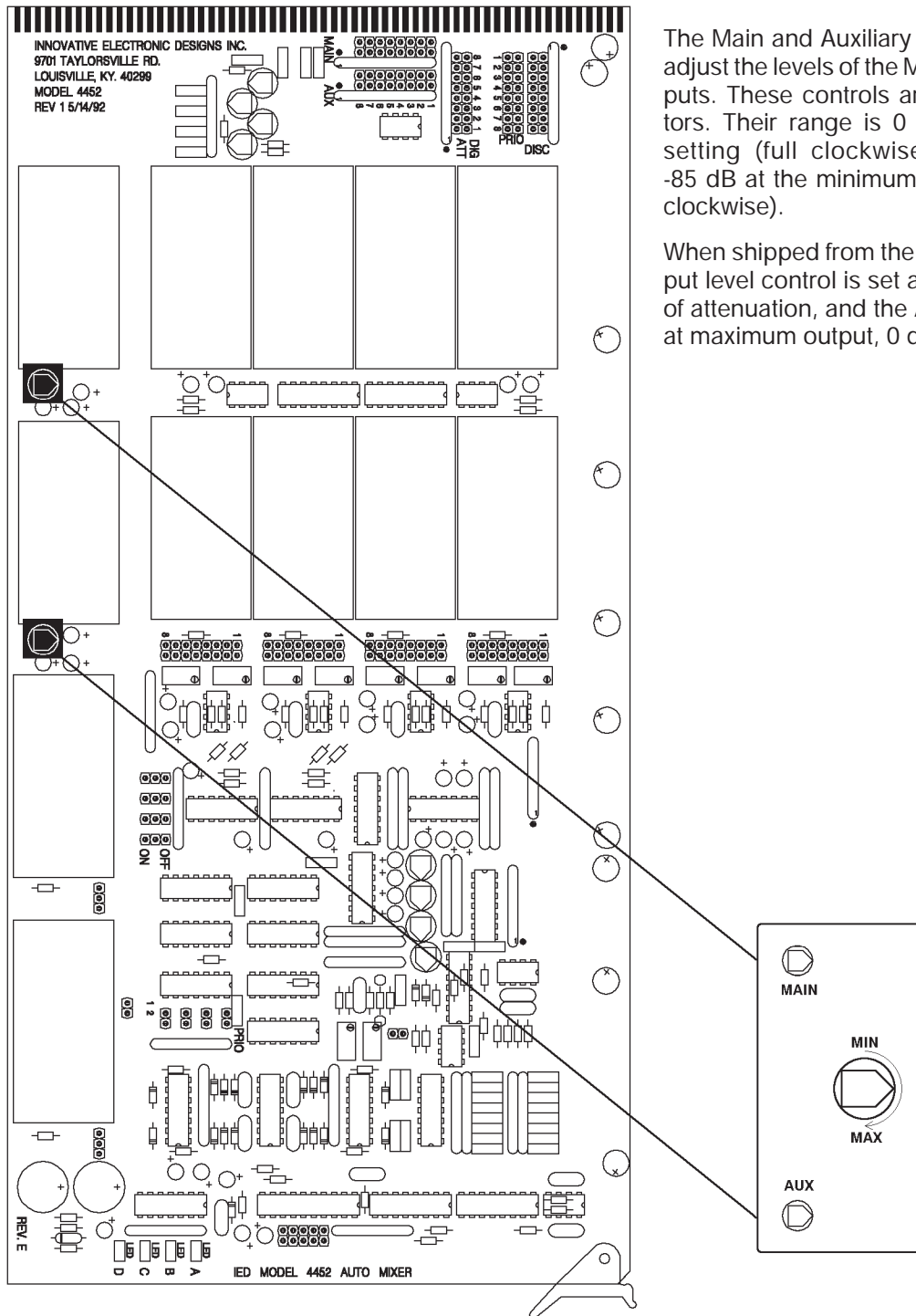

Figure 15 - Release time adjustment of gated inputs

*Innovative Electronic Designs, Inc. • 9701 Taylorsville Road • Louisville, Kentucky 40299 • USA
Phone: (502) 267-7436 • Fax: (502) 267-9070 • Internet: <http://www.iedaudio.com>*

MAIN AND AUXILIARY OUTPUT LEVEL ADJUSTMENT



The Main and Auxiliary Output level controls adjust the levels of the Main and Auxiliary outputs. These controls are full range attenuators. Their range is 0 dB at the maximum setting (full clockwise) to approximately -85 dB at the minimum setting (full counter-clockwise).

When shipped from the factory, the Main output level control is set at approximately 6 dB of attenuation, and the Auxiliary output is set at maximum output, 0 dB of attenuation.

Figure 16 - Setting Main an Auxiliary output levels



FORCE ON OR FORCE OFF OF GATED INPUTS

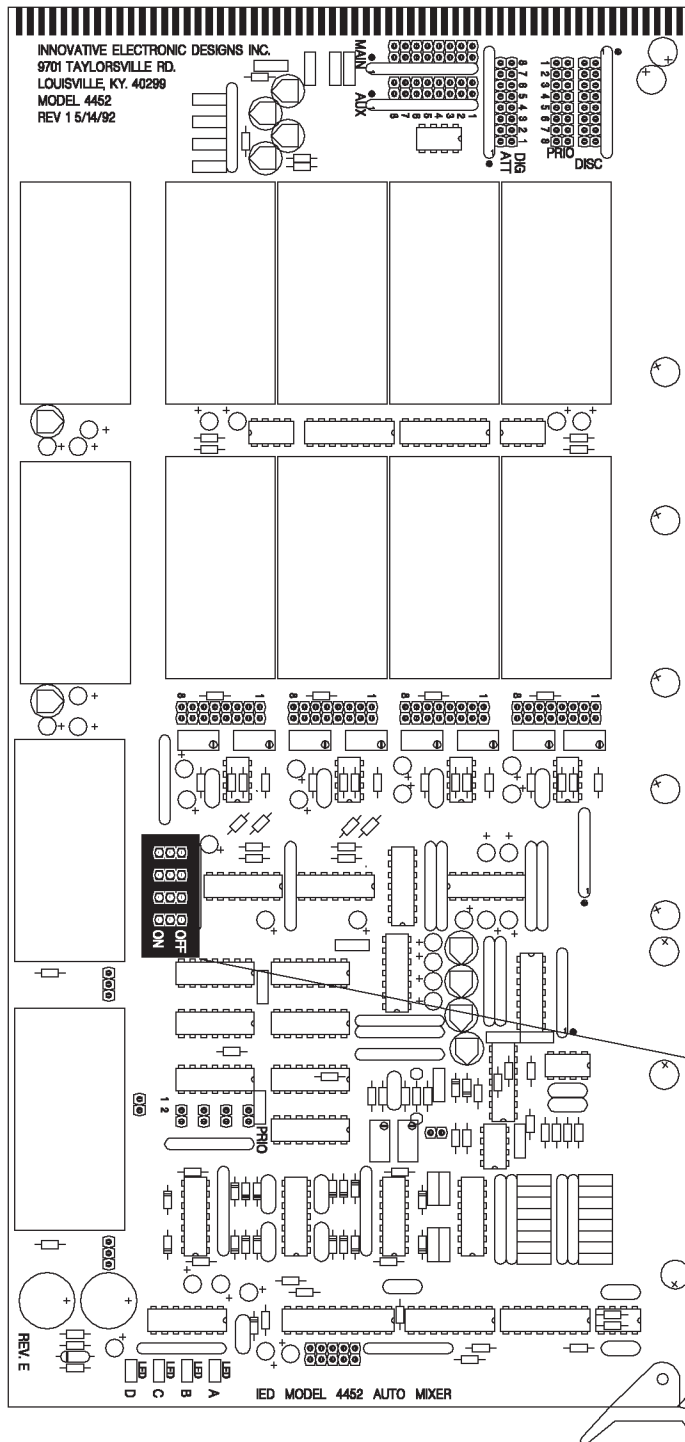

Force On/Force Off - These functions override gating operation and place the input in a continuous ON state or a continuous OFF state, respectively. When an input is forced on it still contributes to the attenuation of the Main Output (Digital Attenuator), to the Fill-buster count, and to the Discriminator, unless specifically removed from these functions by defeating the Digital Attenuator and/or the Discriminator (see pages 21 and 22).

When an input is forced off, it still contributes to the Discriminator, unless specifically removed from this function by defeating the Discriminator (see page 22).

For details of jumper setup, refer to the figure below.

The 4452 Series Automatic Mixers are shipped from the factory with all inputs set for normal gating (no jumpers installed).

Figure 17 - Force On and Force Off for gated inputs
Jumper setup

*Innovative Electronic Designs, Inc. • 9701 Taylorsville Road • Louisville, Kentucky 40299 • USA
Phone: (502) 267-7436 • Fax: (502) 267-9070 • Internet: <http://www.iedaudio.com>*

ENABLING/DISABLING PRIORITY OF GATED INPUTS

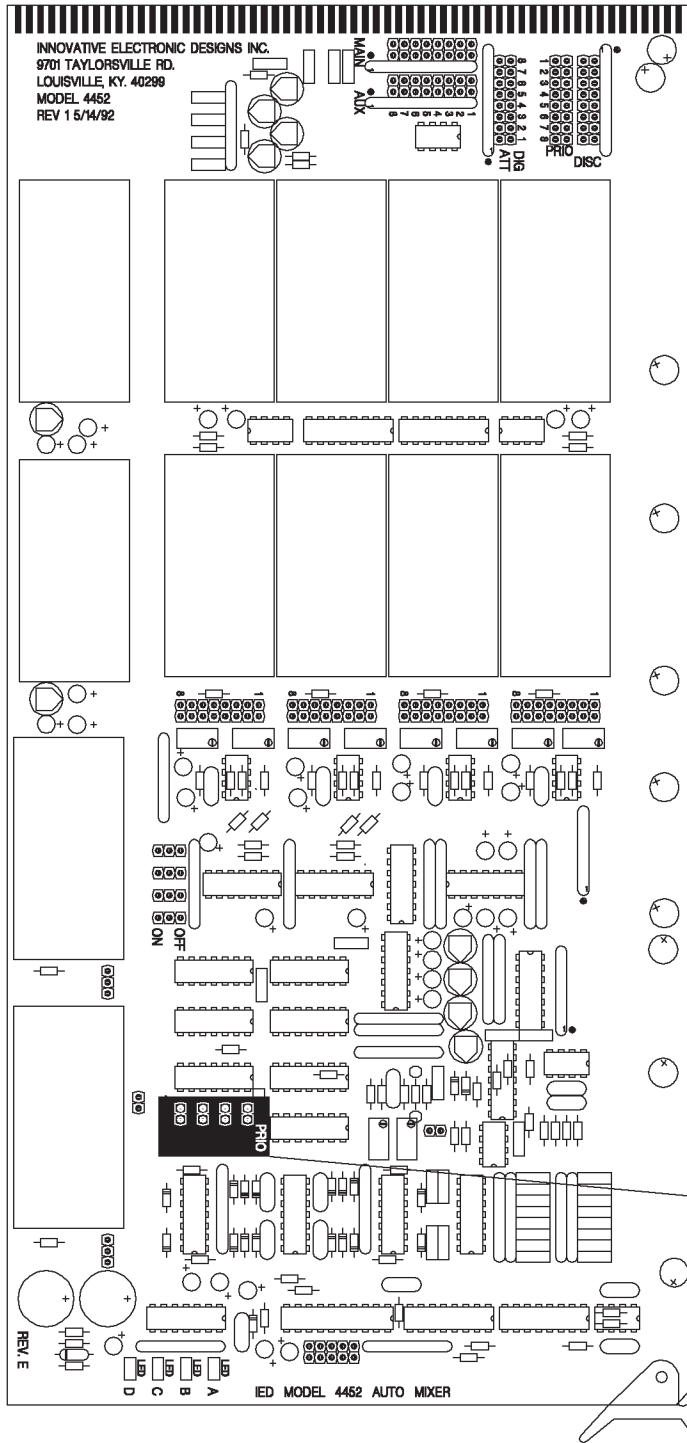

Priority - Priority is the feature, which when enabled for an input allows that input to take precedence over inputs which do not have the priority feature enabled. That is to say that when an input in priority is gated on, other inputs not in priority are immediately caused to gate off. Other inputs which are in priority are not affected. To place an input in priority, place a jumper on the appropriate pins as shown in the figure below. As shipped from the factory, no priority jumpers are in place, and no inputs are in priority.

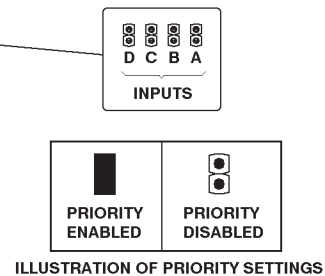
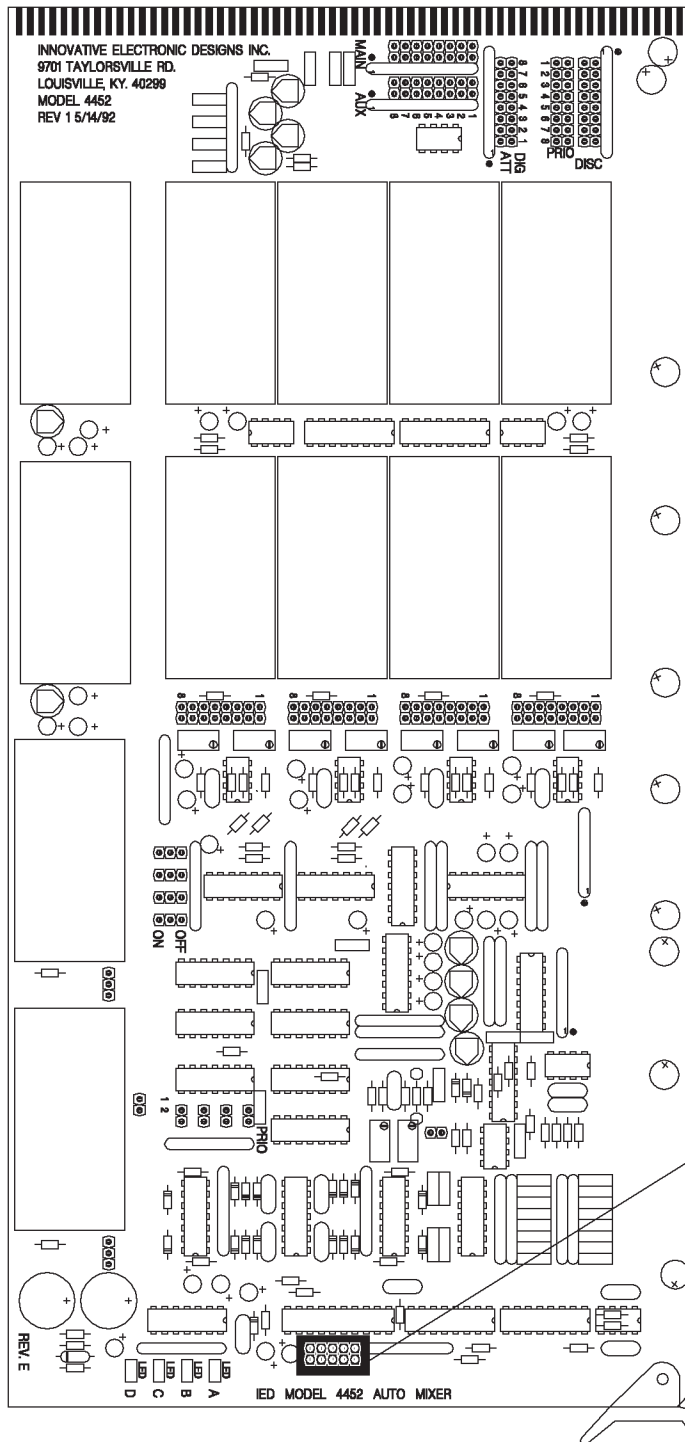

Figure 18 - Enabling/disabling Priority of gated inputs



FILIBUSTER LIMIT SET OF GATED INPUTS



Filibuster - The Filibuster feature limits the maximum number of inputs which can gate on in a given mixer. If mixers are combined or linked, the total number of inputs which are gated on in the combined or linked mixer count toward the limit. The limit can be set at 1, 2, 3, 4, or ALL on each mixer card. The ALL setting defeats the feature. If mixers are combined or linked and the limit on a particular mixer is set for 2, an input on that mixer can gate on only when the total number of inputs which are on on all mixers in the group is less than 2.. **A jumper MUST be placed in one, but not more than one of the positions, or erratic performance may result.** The figure below shows the details of jumper placement. Inputs for which the Digital Attenuator has been defeated do not contribute to or affect the Filibuster limit, although they are still subject to it. As shipped from the factory, there is a jumper in the 'All' position, defeating the Filibuster feature.

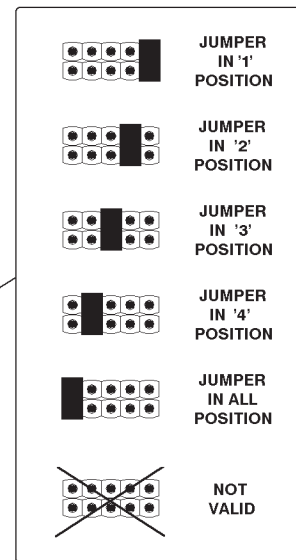
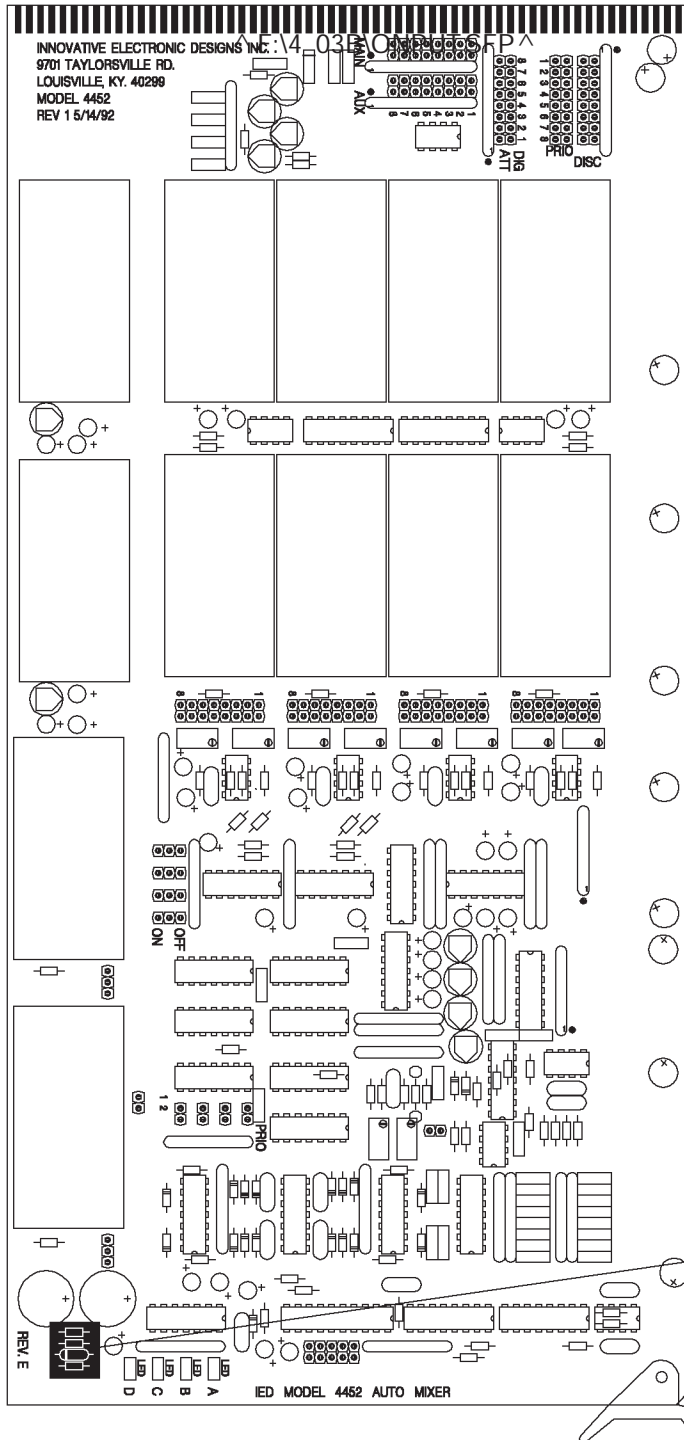

Figure 19 - Filibuster limit set of gated input
Jumper setup

*Innovative Electronic Designs, Inc. • 9701 Taylorsville Road • Louisville, Kentucky 40299 • USA
Phone: (502) 267-7436 • Fax: (502) 267-9070 • Internet: <http://www.iedaudio.com>*

ONPUT OPTION FOR GATED INPUTS



Onput - When the **Onput** feature is enabled, input number 1 is gated on or remains on until another input is gated on in its place. This feature prevents the system from sounding 'dead' by turning on the number 1 input when all other inputs are gated off. Shown below are the details of Onput component placement. When using the **Onput** feature with a combined or linked multi-input mixer, **Onput** must be installed on only one of the mixer cards in that group.

ONPUT COMPONENTS	
Designator	Value
R25	30 kΩ 1/4 W 5%
R30	3 kΩ 1/4 W 5%
D12	1N914
R48	100 kΩ 1/4 W 5%

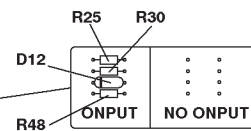

Figure 20 - Onput option for gated inputs



OUTPUT OPTION CONTROL SELECTION

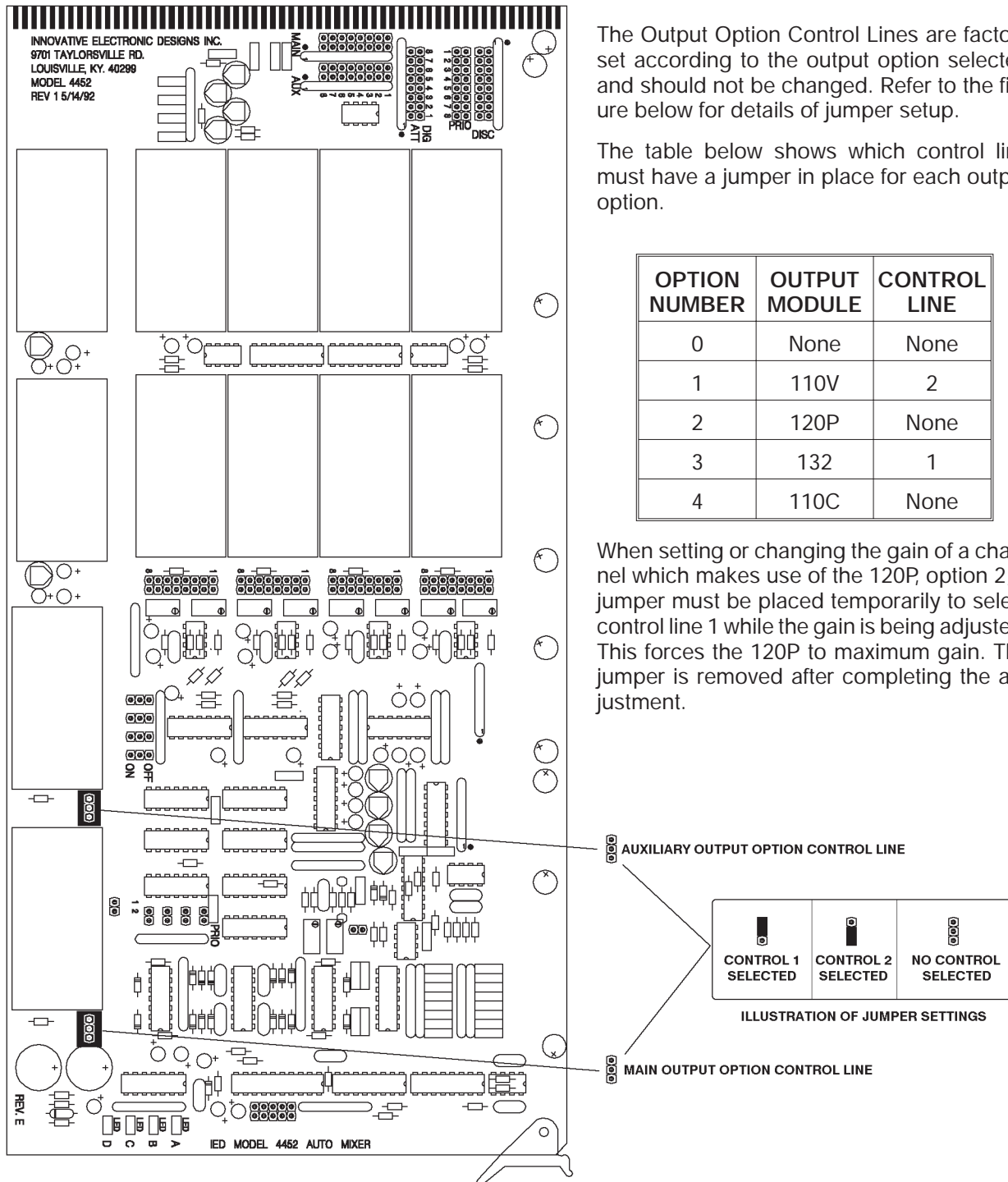
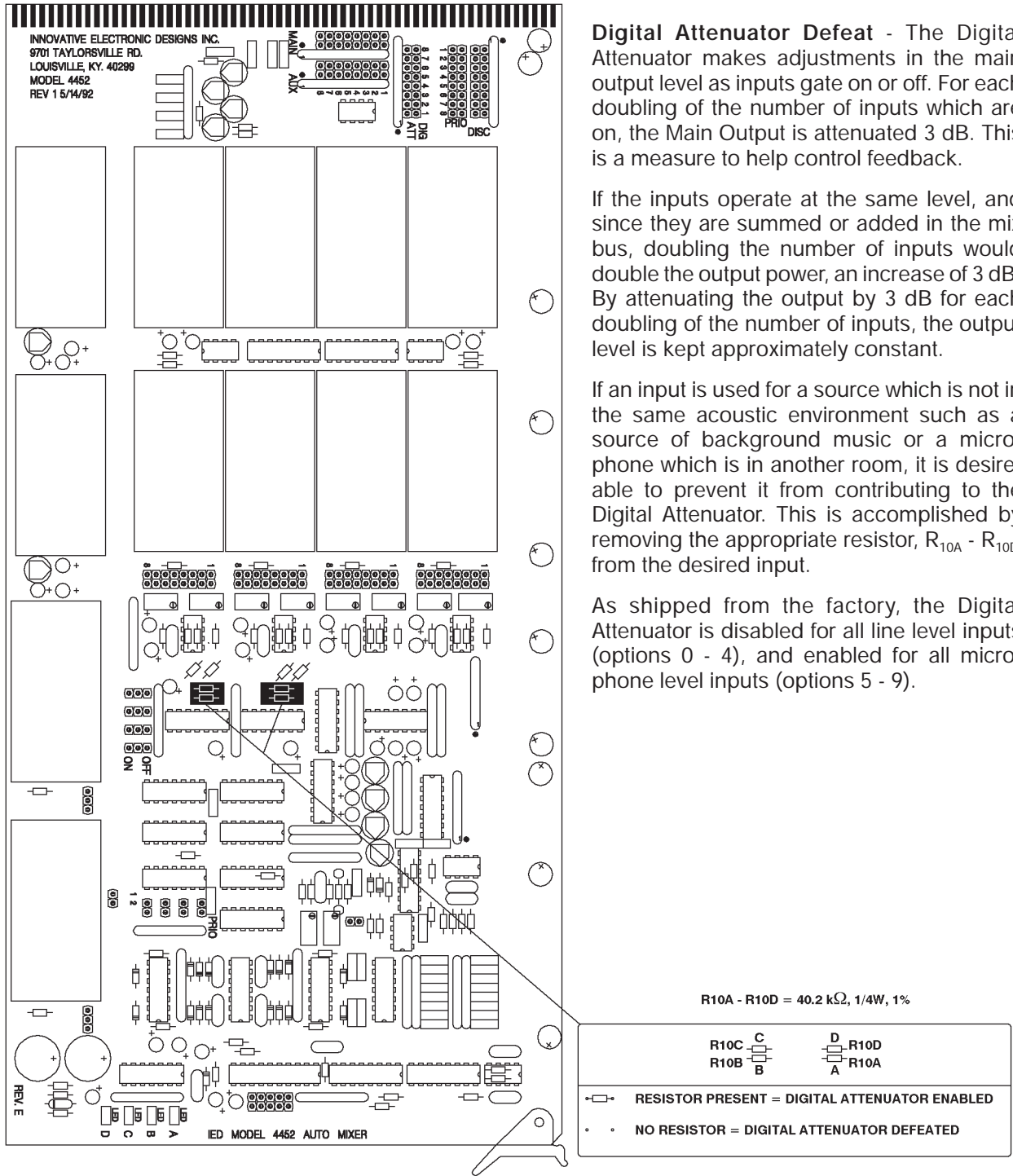

Figure 21 - Output option control selection

*Innovative Electronic Designs, Inc. • 9701 Taylorsville Road • Louisville, Kentucky 40299 • USA
Phone: (502) 267-7436 • Fax: (502) 267-9070 • Internet: <http://www.iedaudio.com>*

DIGITAL ATTENUATOR DEFEAT FOR GATED INPUTS



Digital Attenuator Defeat - The Digital Attenuator makes adjustments in the main output level as inputs gate on or off. For each doubling of the number of inputs which are on, the Main Output is attenuated 3 dB. This is a measure to help control feedback.

If the inputs operate at the same level, and since they are summed or added in the mix bus, doubling the number of inputs would double the output power, an increase of 3 dB. By attenuating the output by 3 dB for each doubling of the number of inputs, the output level is kept approximately constant.

If an input is used for a source which is not in the same acoustic environment such as a source of background music or a microphone which is in another room, it is desirable to prevent it from contributing to the Digital Attenuator. This is accomplished by removing the appropriate resistor, R_{10A} - R_{10D}, from the desired input.

As shipped from the factory, the Digital Attenuator is disabled for all line level inputs (options 0 - 4), and enabled for all microphone level inputs (options 5 - 9).

Figure 22 - Digital Attenuator defeat for gated inputs



DISCRIMINATOR DEFEAT FOR GATED INPUTS

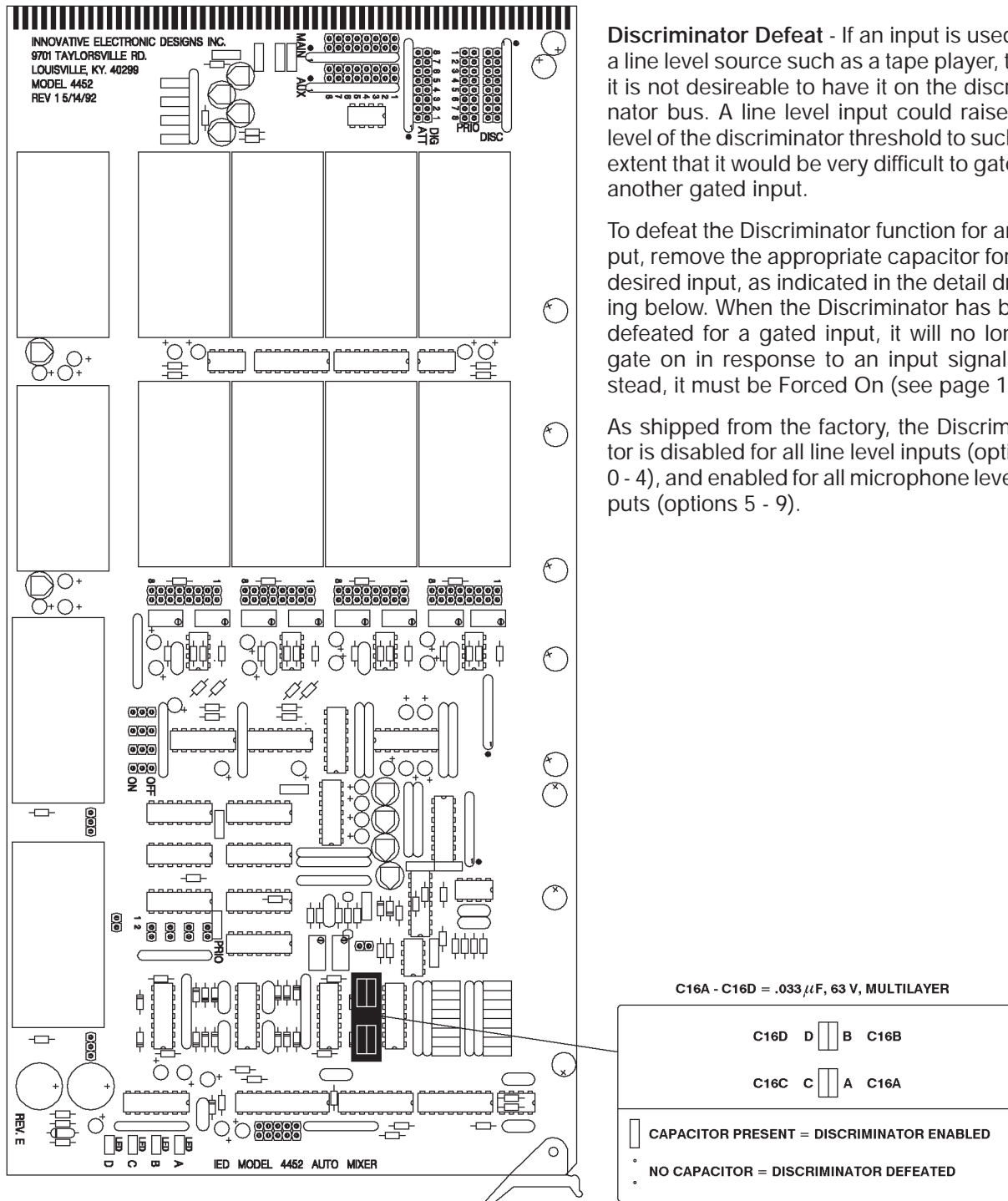

Discriminator Defeat - If an input is used for a line level source such as a tape player, then it is not desirable to have it on the discriminator bus. A line level input could raise the level of the discriminator threshold to such an extent that it would be very difficult to gate on another gated input.

To defeat the Discriminator function for an input, remove the appropriate capacitor for the desired input, as indicated in the detail drawing below. When the Discriminator has been defeated for a gated input, it will no longer gate on in response to an input signal. Instead, it must be Forced On (see page 16).

As shipped from the factory, the Discriminator is disabled for all line level inputs (options 0 - 4), and enabled for all microphone level inputs (options 5 - 9).

Figure 23 - Discriminator defeat for gated inputs

*Innovative Electronic Designs, Inc. • 9701 Taylorsville Road • Louisville, Kentucky 40299 • USA
Phone: (502) 267-7436 • Fax: (502) 267-9070 • Internet: <http://www.iedaudio.com>*

DISCRIMINATOR SENSITIVITY AND OFFSET ADJUSTMENT FOR GATED INPUTS

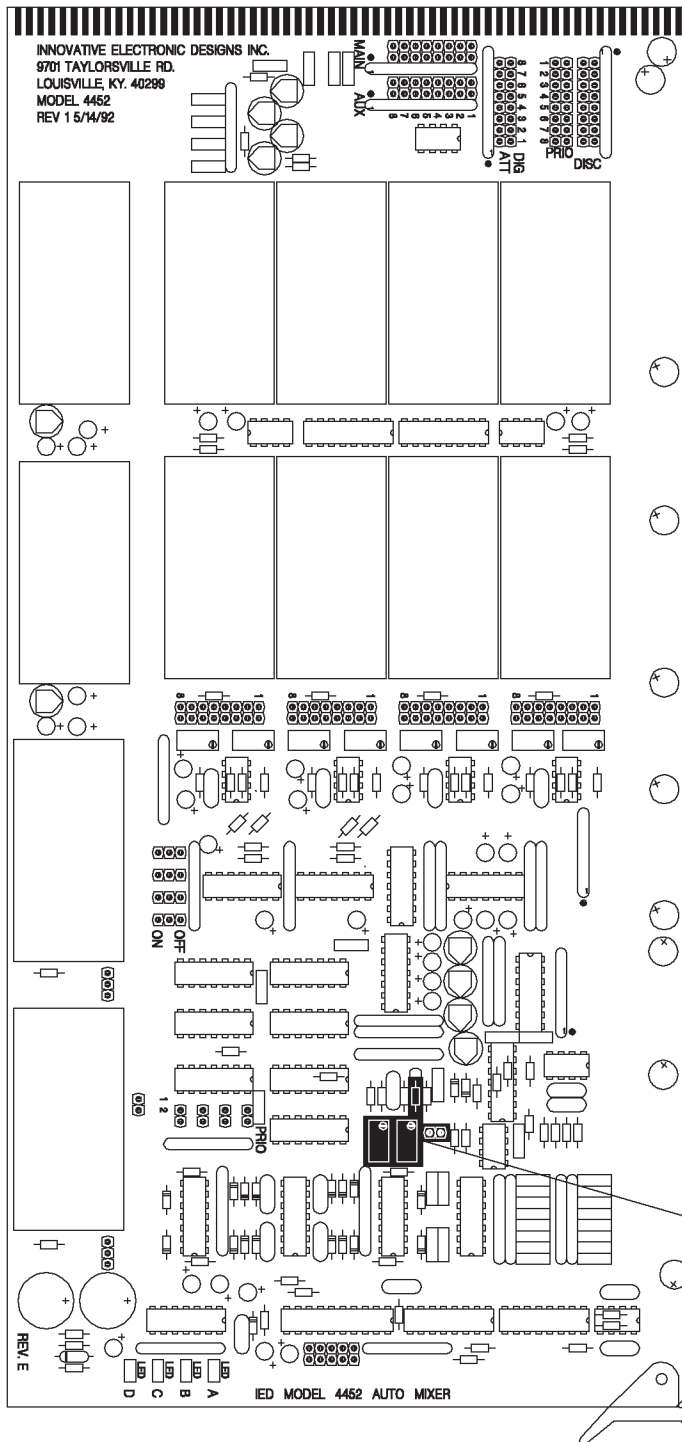

The Discriminator sensitivity and offset depend upon the number of active inputs in the system. These parameters are carefully adjusted at the factory for the specified configuration. They should not be readjusted in the field. If gating problems occur, contact the factory.

Figure 24 - Discriminator sensitivity and offset adjustment for gated inputs



MODEL 4174 MAINFRAME REAR TERMINAL IDENTIFICATION

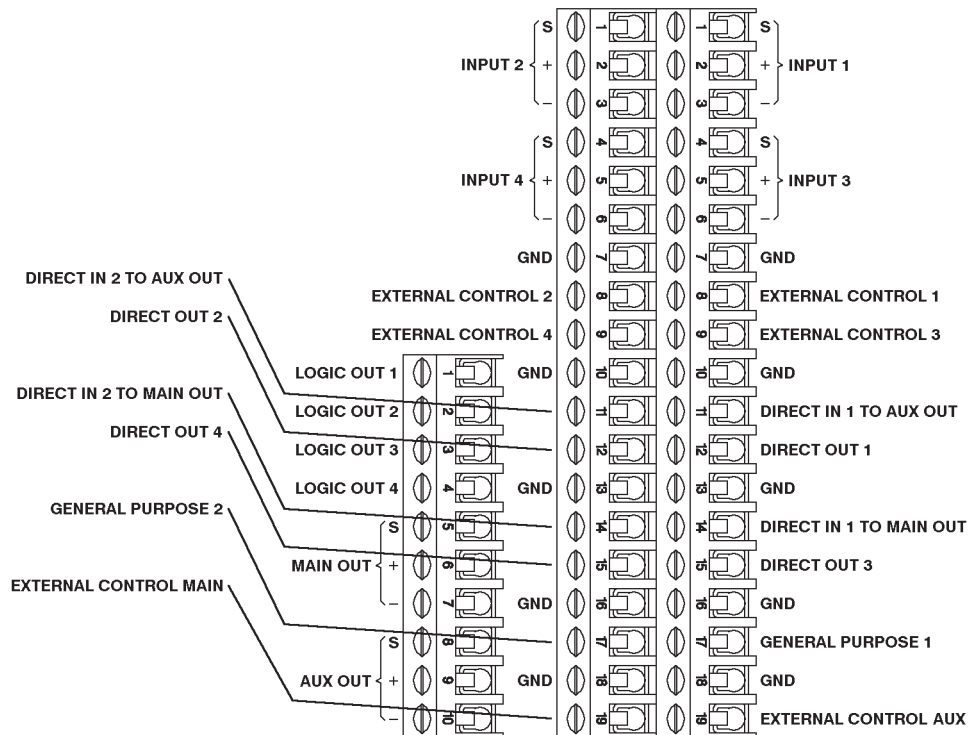

Figure 25 - Model 4174 Mainframe rear terminal identification

*Innovative Electronic Designs, Inc. • 9701 Taylorsville Road • Louisville, Kentucky 40299 • USA
 Phone: (502) 267-7436 • Fax: (502) 267-9070 • Internet: <http://www.iedaudio.com>*

TYPICAL GATED INPUT CONNECTIONS

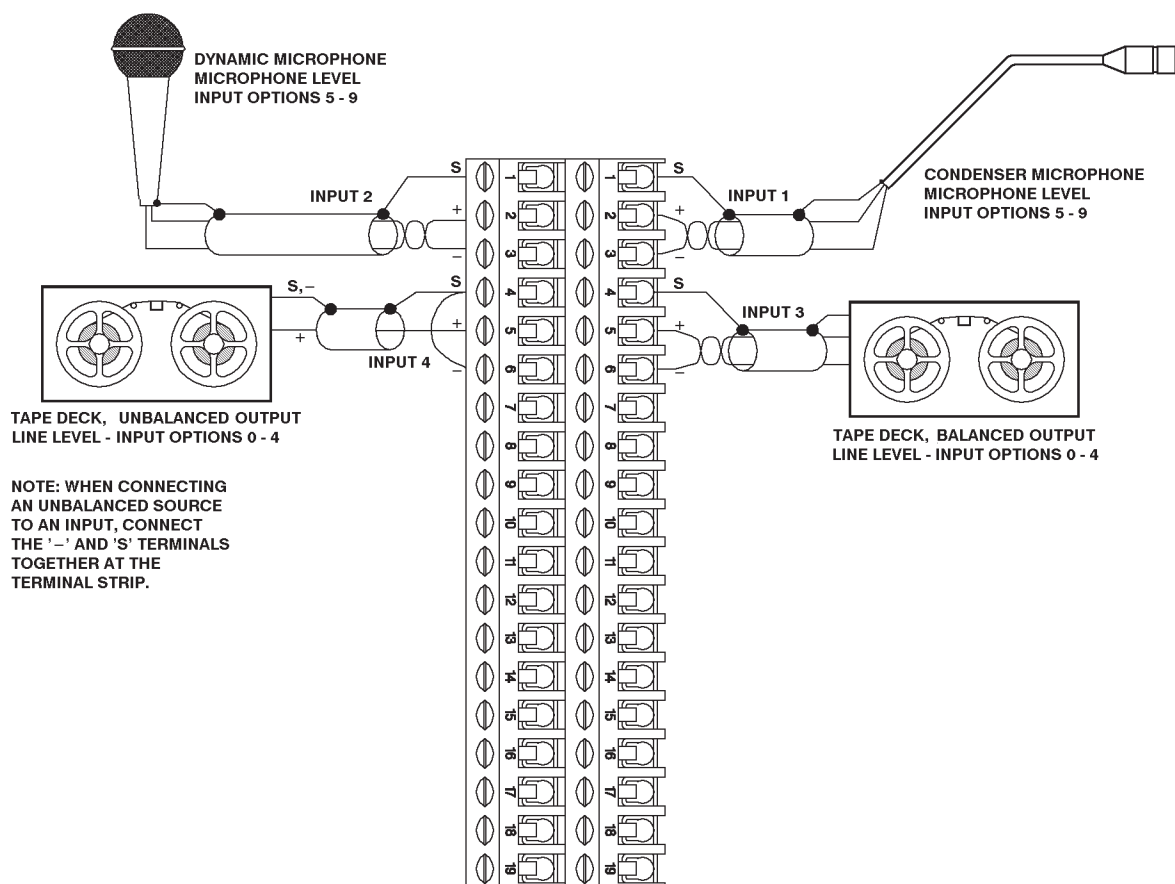

Figure 26 - Typical gated input connections

TYPICAL DIRECT INPUT CONNECTIONS

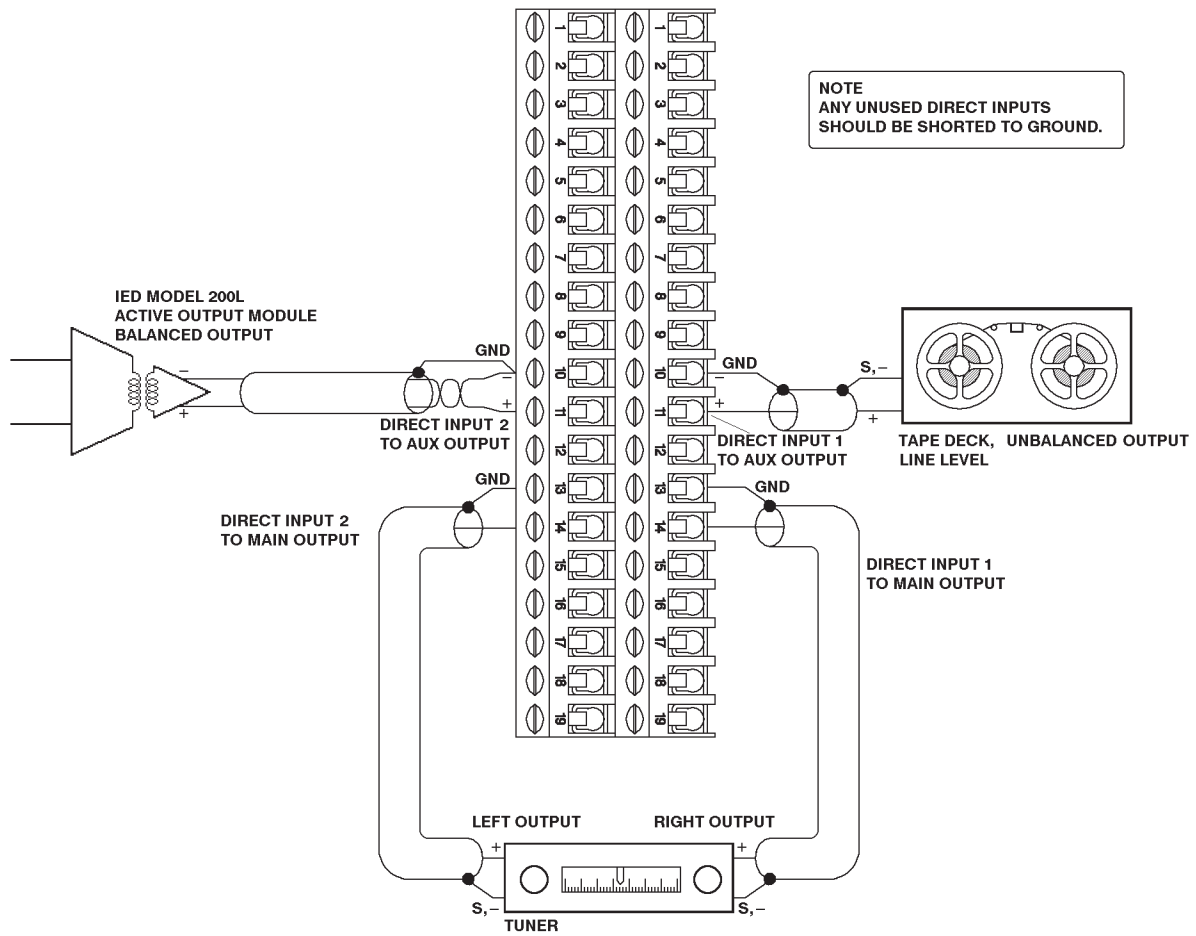

Figure 27 - Typical Direct Input connections

*Innovative Electronic Designs, Inc. • 9701 Taylorsville Road • Louisville, Kentucky 40299 • USA
 Phone: (502) 267-7436 • Fax: (502) 267-9070 • Internet: <http://www.iedaudio.com>*

MAIN AND AUXILIARY OUTPUT CONNECTIONS TO BALANCED LOADS

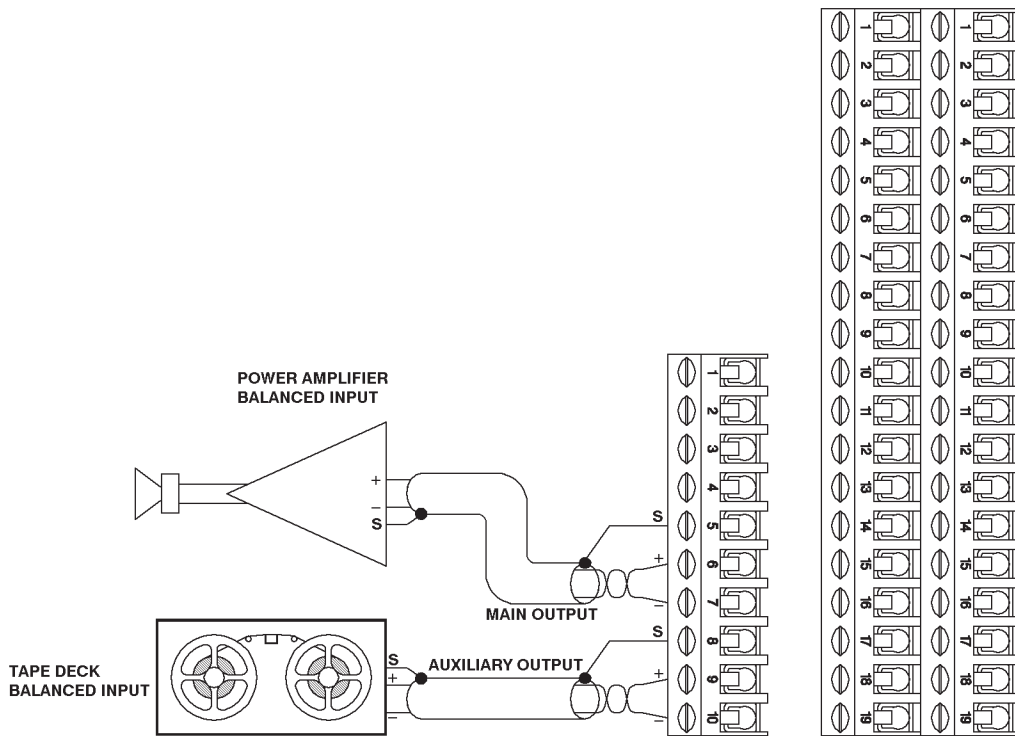

Figure 28 - Typical Main and Auxiliary output connections to balanced loads

MAIN AND AUXILIARY OUTPUT CONNECTIONS TO UNBALANCED LOADS

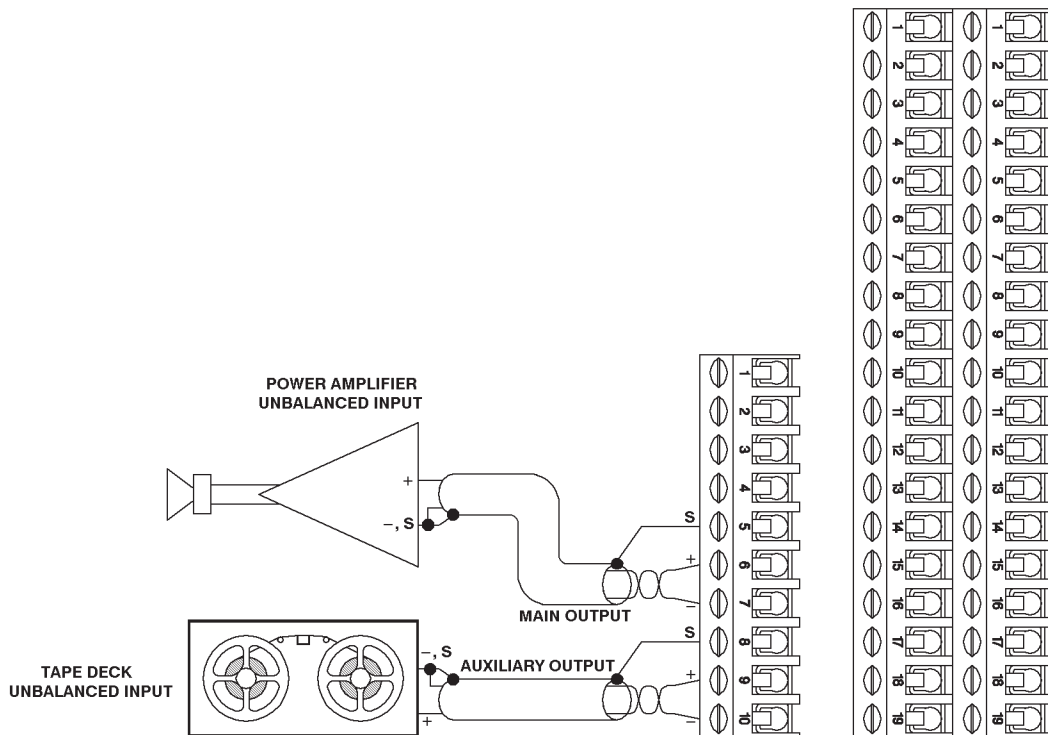

Figure 29 - Typical Main and Auxiliary Output connections to unbalanced loads

*Innovative Electronic Designs, Inc. • 9701 Taylorsville Road • Louisville, Kentucky 40299 • USA
 Phone: (502) 267-7436 • Fax: (502) 267-9070 • Internet: <http://www.iedaudio.com>*

TYPICAL DIRECT OUTPUT CONNECTIONS

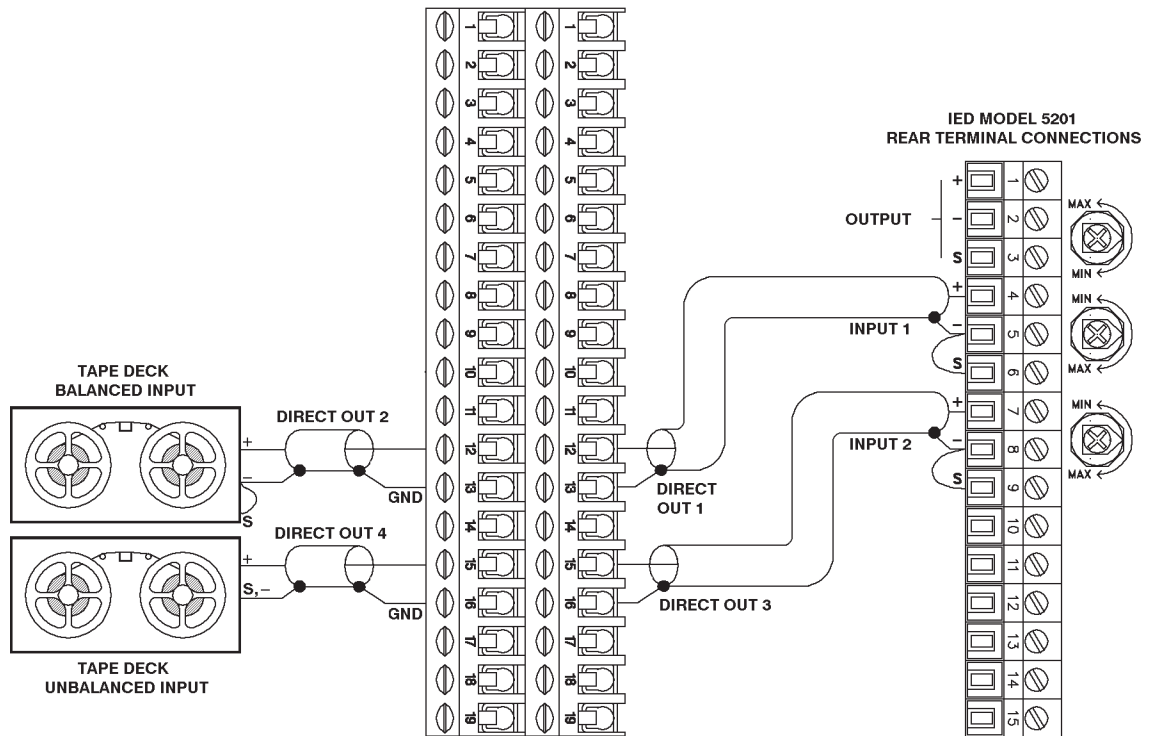

Figure 30 - Typical Direct Output connections



USING THE 112PLC TO CONTROL THE LEVELS OF INPUTS AND OUTPUTS WHICH HAVE THE MODEL 132 VCDA

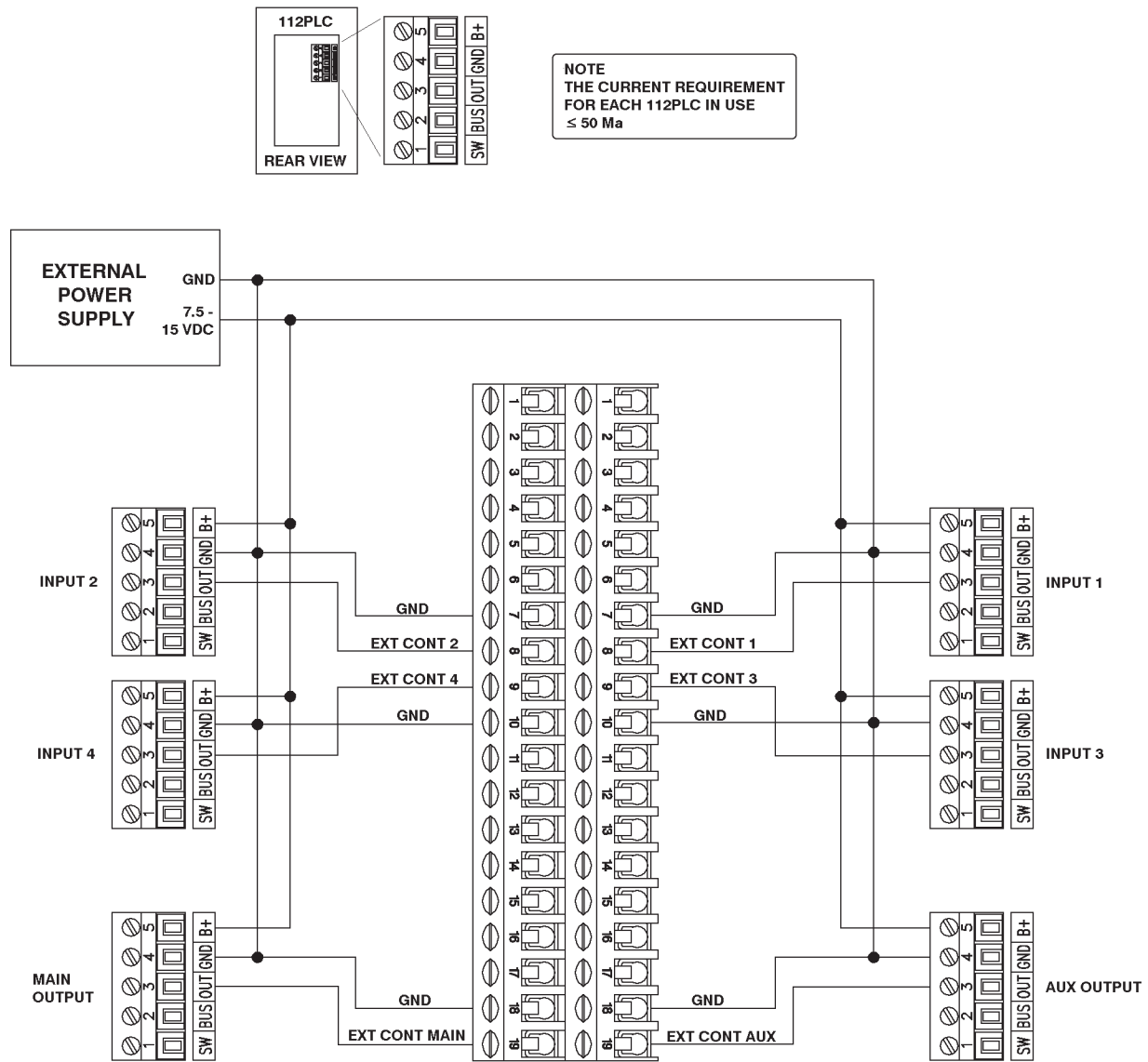

Figure 31 - Controlling input and output levels with the 112PLC Pushbutton Level Control

*Innovative Electronic Designs, Inc. • 9701 Taylorsville Road • Louisville, Kentucky 40299 • USA
Phone: (502) 267-7436 • Fax: (502) 267-9070 • Internet: <http://www.iedaudio.com>*

USING ROTARY POTS TO CONTROL THE LEVELS OF INPUTS AND OUTPUTS WHICH HAVE THE MODEL 132 VCDA

NOTES

WIRING SHOWN IS FOR INPUT OPTIONS 3 AND 8, AND FOR OUTPUT OPTION 3 ON EITHER THE MAIN OR AUXILIARY OUTPUT. THESE OPTIONS MAKE USE OF THE MODEL 132 VOLTAGE CONTROLLED DIGITAL ATTENUATOR (VCDA). THE MODEL 132 REQUIRES A +5 V REFERENCE. +5 V IS WIRED ON THE PRINTED CIRCUIT BOARD TO ONE OR BOTH OF THE GENERAL PURPOSE CONNECTIONS, TERMINAL 17, AS NEEDED FOR CLOSEST ACCESS. INPUTS 1 AND 3, AND THE AUX OUTPUT RECEIVE +5 V FROM GP 1. INPUTS 2 AND 4, AND THE MAIN OUTPUT RECEIVE +5 V FROM GP 2.

CONNECTIONS ARE MADE USING 22 AWG SHIELDED TWISTED PAIR, BELDEN 8451 OR EQUIVALENT.

THE MAXIMUM NUMBER OF POTS FOR EACH REFERENCE = 4

SIGNAL LEVEL INCREASES WITH CLOCKWISE POT ROTATION

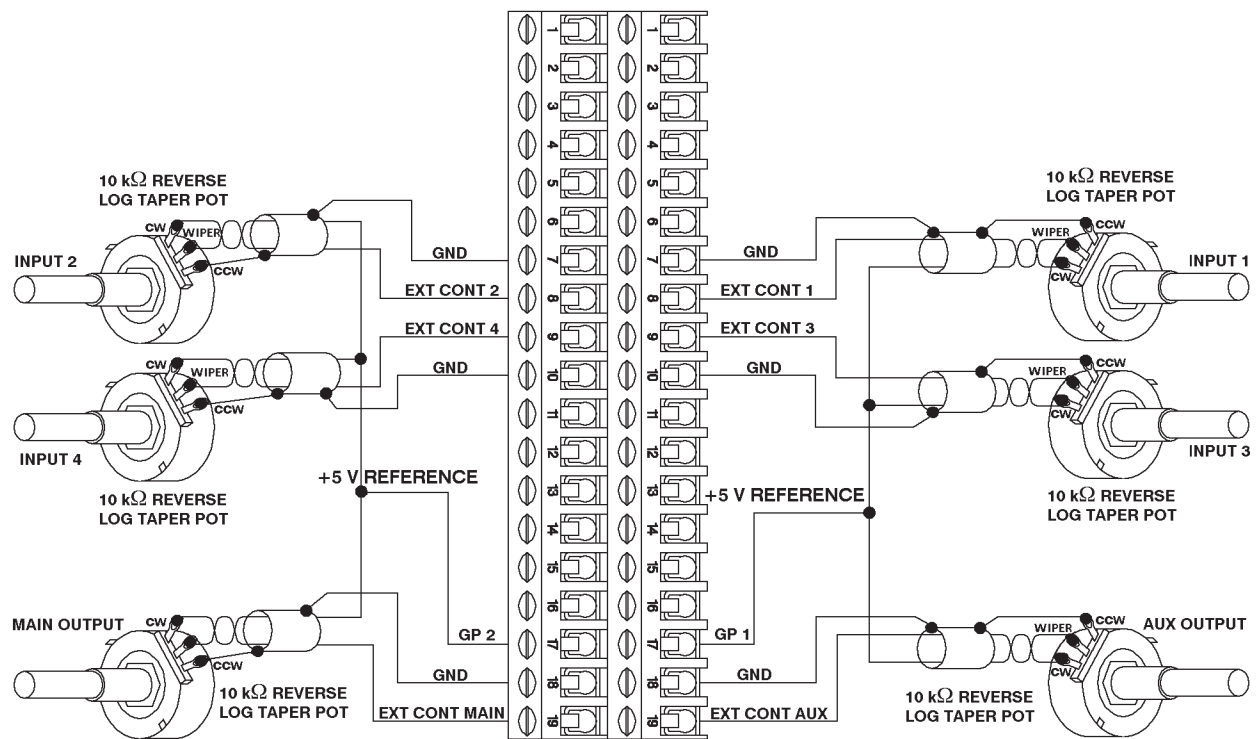

Figure 32 - Controlling input and output levels with the Model 132 Voltage Controlled Digital Attenuator (VCDA)



CONTROLLING INPUT AND OUTPUT LEVELS WITH THE MODEL 110V VCA

NOTES:

WIRING SHOWN IS FOR INPUT OPTIONS 1 AND 6 AND FOR OUTPUT OPTION 1 ON EITHER THE MAIN OR AUXILIARY OUTPUT. THESE OPTIONS USE THE 110V VOLTAGE CONTROLLED AMPLIFIER (VCA). CONNECTIONS ARE MADE USING 22 AWG TWISTED PAIR.

NOTE THAT THE WIPER OF EACH POT IS CONNECTED TO THE CLOCKWISE END.

SIGNAL LEVEL INCREASES WITH CLOCKWISE POT ROTATION

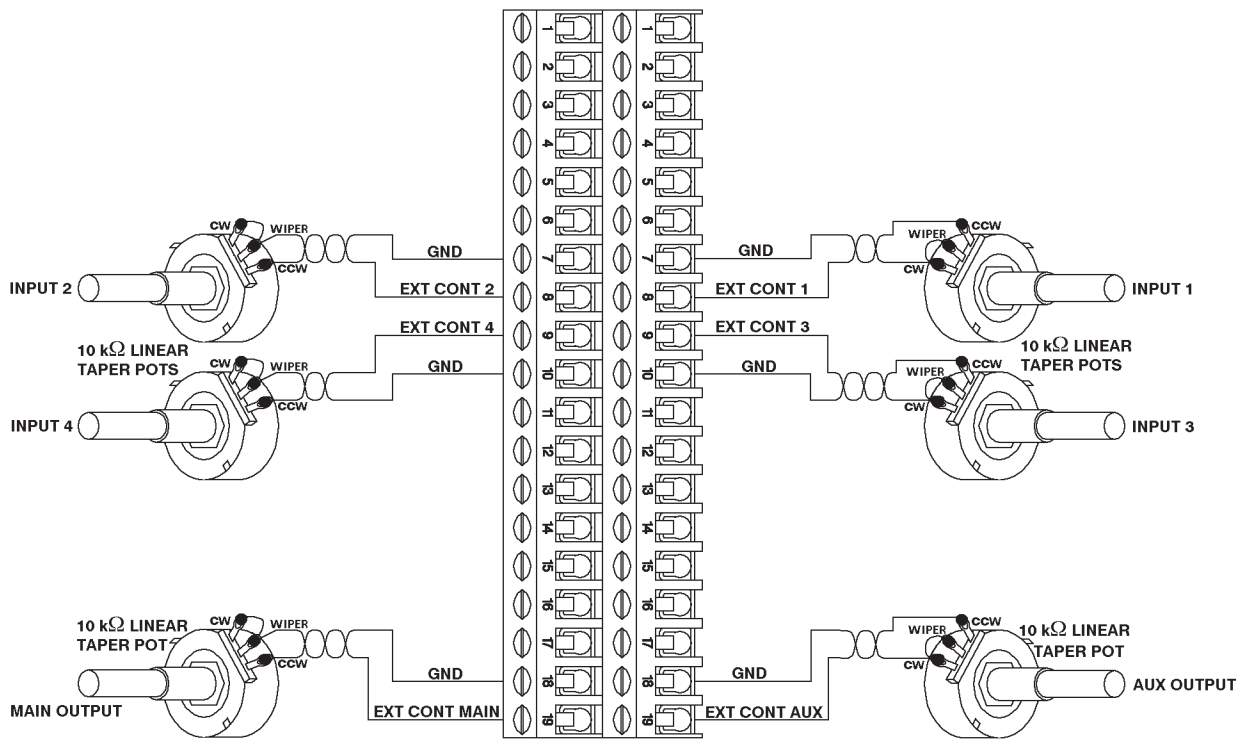

Figure 33 - Controlling input and output levels with the Model 110V Voltage Controlled Amplifier (VCA)

*Innovative Electronic Designs, Inc. • 9701 Taylorsville Road • Louisville, Kentucky 40299 • USA
 Phone: (502) 267-7436 • Fax: (502) 267-9070 • Internet: <http://www.iedaudio.com>*

REMOTE CHANNEL ON INDICATORS USING THE LOGIC OUTPUTS

NOTES: WHEN AN INPUT GATES ON, ITS LOGIC OUTPUT SWITCHES FROM +5 V TO 0 V (5 mA MAX).
THIS CIRCUIT APPLIES ONLY WHEN U17 IS 74HC04. SEE PAGE 1.

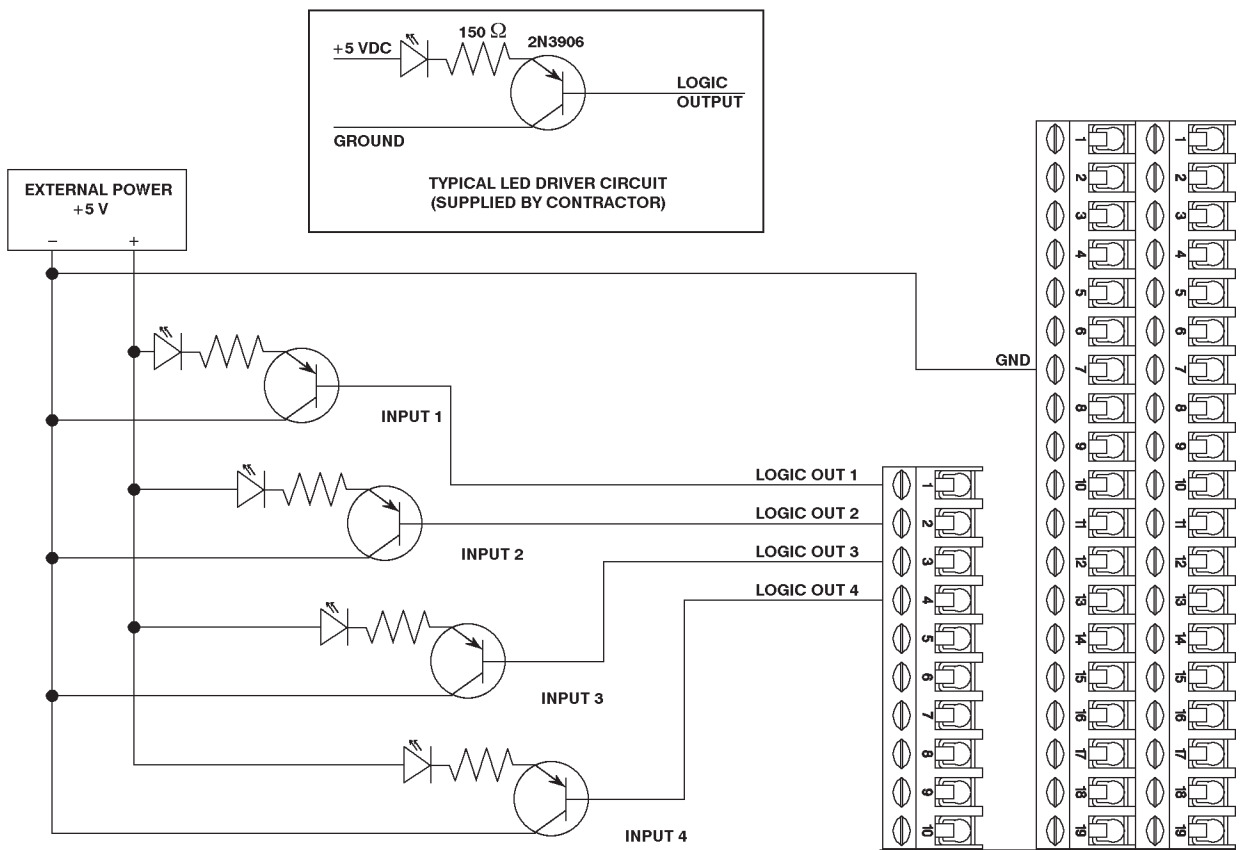

Figure 34 - Remote Channel On indicators using the Logic Outputs

REMOTE MANUAL CONTROL OF FORCE ON/OFF USING THE LOGIC OUTPUTS

NOTES:

IF A FORCE ON OR FORCE OFF FUNCTION IS REQUIRED WHICH MAY BE ACTUATED MANUALLY BY AN EXTERNAL SWITCH, AND THE LOGIC OUT FUNCTIONS ARE NOT NEEDED, THEN THE FORCE ON OR FORCE OFF FUNCTIONS MAY BE WIRED INTERNALLY TO THE LOGIC OUT TERMINALS. THE GP 1 TERMINAL IS USED TO SUPPLY +5 V.

WHEN WIRED AS SHOWN, THE CHANNEL WILL BE FORCED ON OR OFF WHEN THE CORRESPONDING SWITCH IS CLOSED.

THIS IS A CUSTOM SETUP DONE AT THE FACTORY

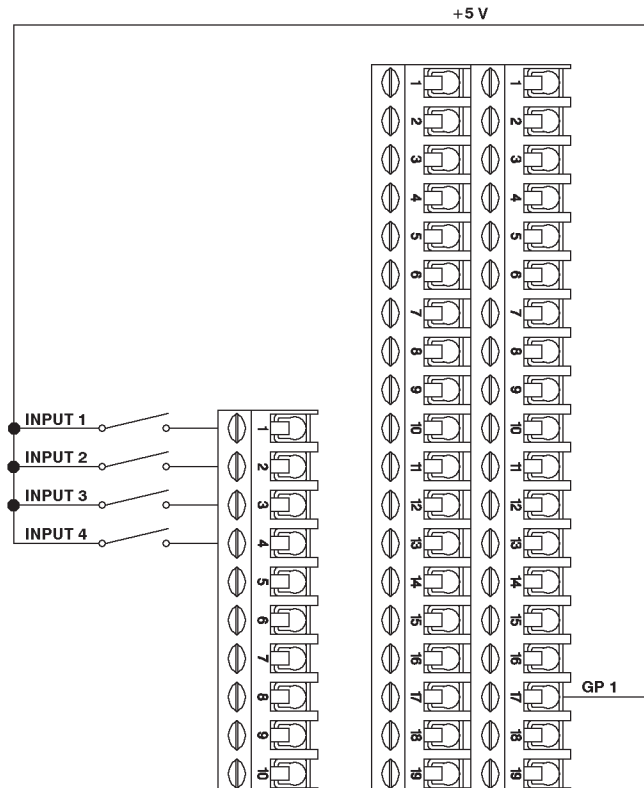

Figure 35 - Remote manual control of Force On/Off using Logic Outputs

*Innovative Electronic Designs, Inc. • 9701 Taylorsville Road • Louisville, Kentucky 40299 • USA
 Phone: (502) 267-7436 • Fax: (502) 267-9070 • Internet: <http://www.iedaudio.com>*

REMOTE MANUAL CONTROL OF FORCE ON/OFF USING THE DIRECT INPUTS

NOTES:

IF A FORCE ON OR FORCE OFF FUNCTION IS REQUIRED WHICH MAY BE ACTUATED MANUALLY BY AN EXTERNAL SWITCH, AND THE DIRECT INPUT FUNCTIONS ARE NOT NEEDED, THEN THE FORCE ON OR FORCE OFF FUNCTIONS MAY BE WIRED INTERNALLY TO THE DIRECT INPUT TERMINALS. THE GP 1 TERMINAL IS USED TO SUPPLY +5 V.

WHEN WIRED AS SHOWN, THE CHANNEL WILL BE FORCED ON OR OFF WHEN THE CORRESPONDING SWITCH IS CLOSED.

THIS IS A CUSTOM SETUP DONE AT THE FACTORY

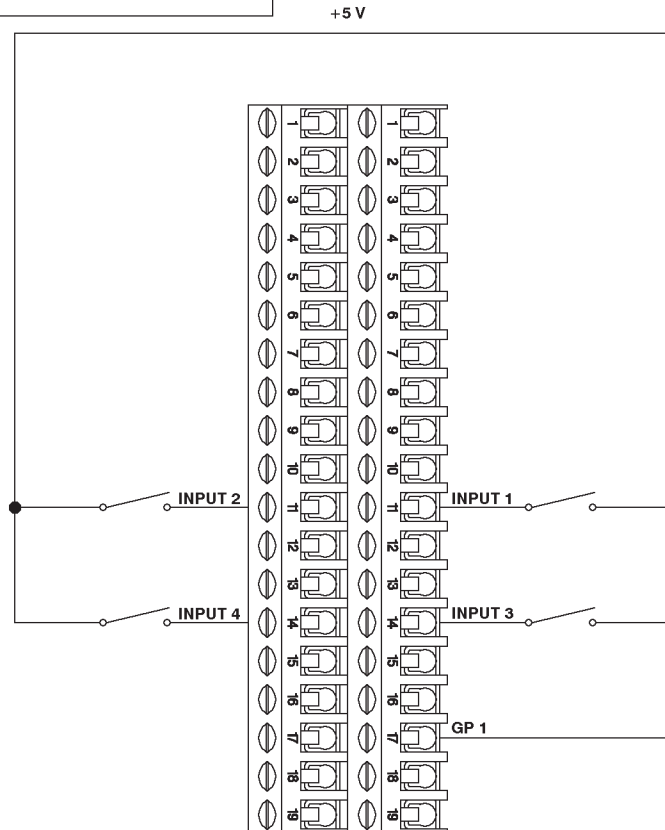

Figure 36 - Remote manual control of Force On/Off using Direct Inputs

This page left blank intentionally

*Innovative Electronic Designs, Inc. • 9701 Taylorsville Road • Louisville, Kentucky 40299 • USA
Phone: (502) 267-7436 • Fax: (502) 267-9070 • Internet: <http://www.iedaudio.com>*