

**MODEL 430L/H****POWER SUPPLIES**

The Models 430L and 430H Power Supplies are components of the IED 400 Power Supply Series.

The 430L is a +30 VDC at 6 A supply whose input voltage range is 105 VAC to 130 VAC. The 430H is a +30 VDC at 6 A supply whose input voltage range is 210 VAC to 260 VAC.

Two alternatives are supported for field service, fuse replacement and replacement of the power supply unit. Other component level field service is not recommended and not supported. The power supply cards are designed to be replaced easily in the field.

If a power supply fault condition is indicated, power down the supplies by disconnecting the power cord from the rear of the 408L/H Mainframe. Remove all the individual power supplies by loosening the two captive, slotted thumbscrews, either with the fingers or with a straight bladed screwdriver. The thumbscrews are located on the front panel of each power supply unit, near the top and bottom. After loosening, extract the supply by grasping both of the thumbscrews and pulling the unit straight out of the frame.

Referring to figure 1, locate each fuse and remove it by carefully pulling it away from the circuit board. Check the fuse for continuity with an ohmmeter, continuity meter, or fuse checker. If an ohmmeter is used, the reading for a good fuse should be  $5 \Omega$  or less. The resistance reading of an open fuse should be in the multi megohm range. Be careful not to bridge the circuit with your fingers or a false reading might result. Replace any defective fuse(s) with another of the type and value specified by IED.

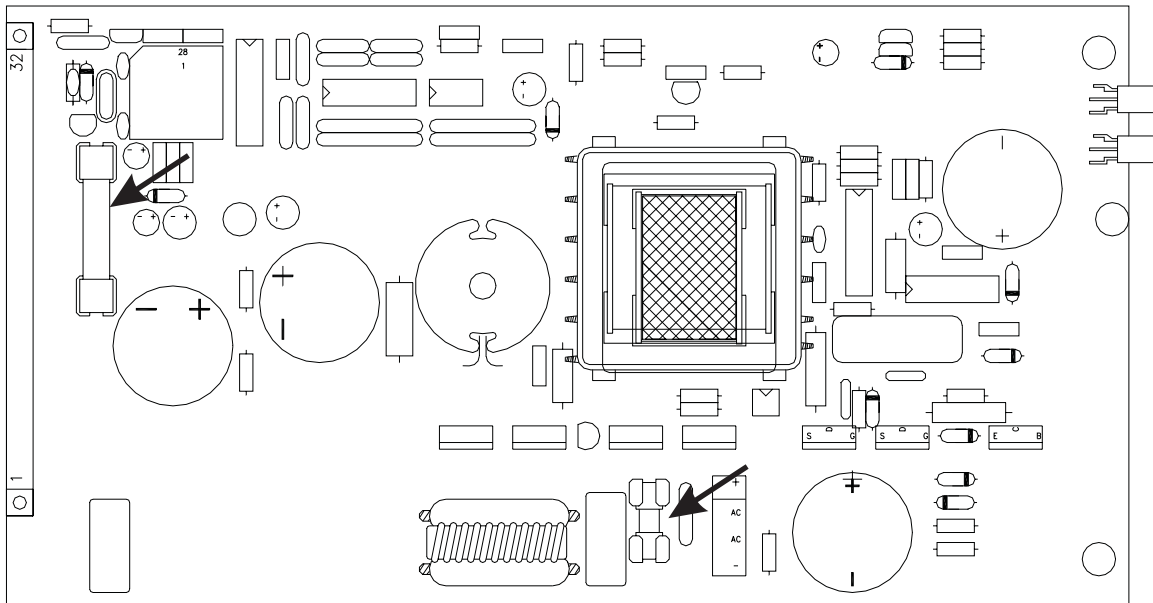

Figure 1 - 430L/H Fuse Location



All power supply card must now be checked individually for proper voltage output. To do this, replace one power supply card (only one) into the 408L/H mainframe. The replacement procedure is the reverse of removal. Reconnect the power cord and check the voltage at the test points provided on the rear of the mainframe. Refer to Figure 2 for their exact location. The voltage must be within the limits stated in the IED specifications for the power supply, Section 10, Group 68, Sub A. Repeat for the remainder of the power supply cards, one at a time. Replace any cards whose voltage is not within specified limits with new cards obtained from the factory.

When all power supply cards are within voltage specifications, power down, replace all power supply cards in the mainframe, then power up and check system operation.

If problems continue, contact IED Customer Service for assistance.

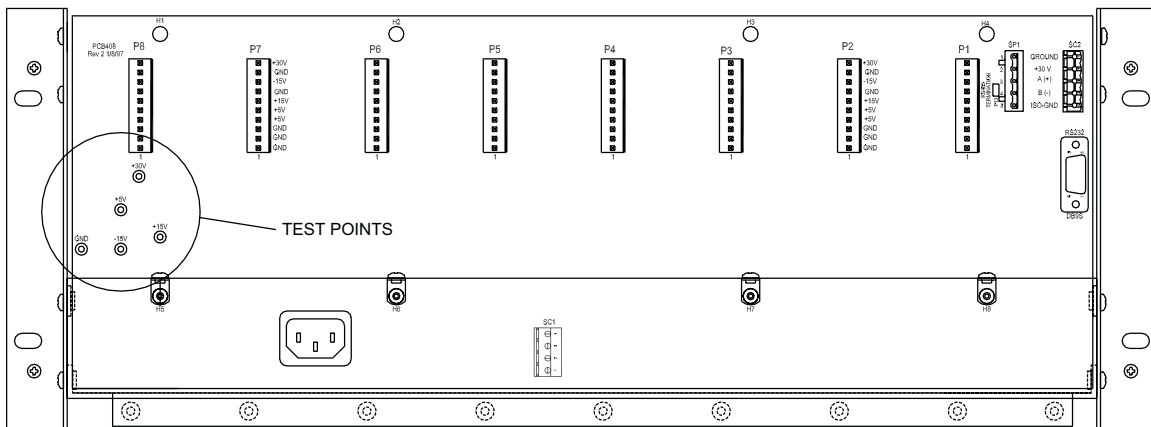

Figure 2 - 408ML/H Mainframe  
Rear view showing test point location

*Innovative Electronic Designs, Inc. • 9701 Taylorsville Road • Louisville, Kentucky 40299 • USA  
Phone: (502) 267-7436 • Fax: (502) 267-9070 • Internet: <http://www.iedaudio.com>*