

## MODEL 2008RY MULTIFUNCTION RELAY CARD

The Model 2008RY Multifunction Relay Card is a component of the IED 2000 Series UDAPS™. The card contains 8 relays and associated drive circuitry which are factory configurable in any of 4 options. The options are listed in Table 1. Options may be used in any combination.

**Option A** - The relay is driven by logic determined by the software. When the relay is not energized, the '+' and '-' channel inputs are open. When the relay is energized, the '+' and '-' channel inputs are connected to the '+' and '-' inputs of the test bus, respectively. Typically, this option is used for testing.

**Option B** - The relay is driven by logic determined by the software. When the relay is not energized, the '+' and '-' channel inputs are open. When the relay is energized, the channel input '+' is connected to the channel input '-'. Typically this option might be used for, but not limited to, muting.

**Option C** - The relay is driven by logic determined by the software. When the relay is not energized, the '+' channel input is connected to ground, and the '-' channel input is connected to +5 V. When the relay is energized, the channel input connections are reversed. The '-' channel input is connected to ground, and the '+' channel input is connected to +5 V. Typically, this option might be used for driving external loads such as relays or LED indicators.

**Option D** - The channel '+' input is set up as a sensing input of a closure to ground. The relay is driven by logic determined by the software and also by the state of the channel '+' input, as needed. This option might typically be used to sense a switch closure, then drive an LED indicator corresponding to the switch closure.

OPTION	RELAY STATUS	RELAY FUNCTION
A	Deenergized	Channel inputs open
	Energized	Channel inputs '+' and '-' connected to the test bus '+' and '-', respectively
B	Deenergized	Channel inputs open
	Energized	Channel '+' connected to channel '-'
C	Deenergized	Channel '+' to ground, '-' to +5 V
	Energized	Channel '-' to ground, '+' to +5 V
D	Deenergized	Channel 1 '-' to +5 V through 10 k $\Omega$ resistor
	Energized	Channel 1 '-' to ground
	n/a	If channel '+' is connected to ground, the UDAPS™ senses a logic change

Table 1 - Relay Options



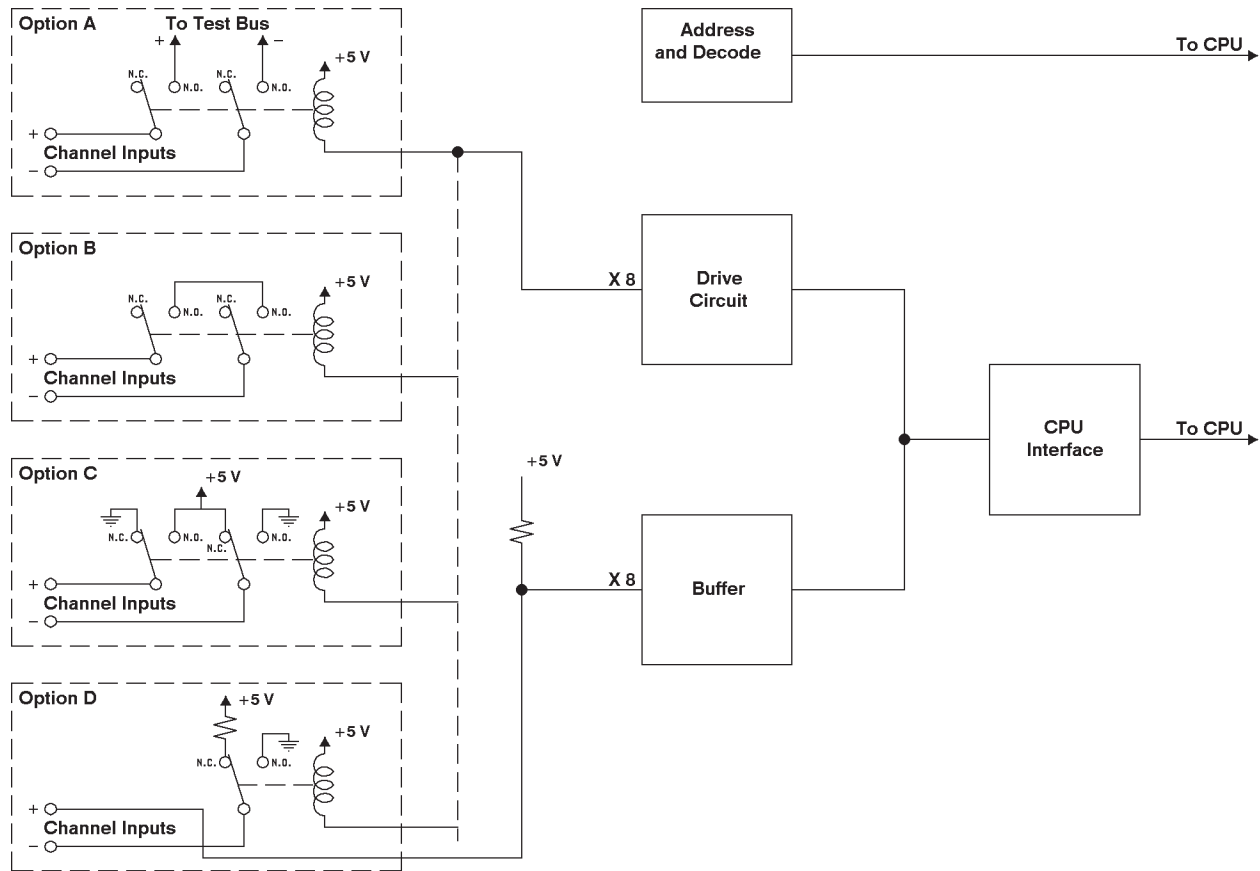

Figure 1 - 2008RY Block Diagram

The functional block diagram for the Model 2008RY is shown in figure 1. Each of the four options is illustrated only once, although the card contains eight relays. All options utilize the drive circuit. Only the 'D' option requires the buffer which is used for the sense signal.

*Innovative Electronic Designs, Inc. • 9701 Taylorsville Road • Louisville, Kentucky 40299 • USA  
 Phone: (502) 267-7436 • Fax: (502) 267-9070 • Internet: <http://www.iedaudio.com>*

**SPECIFICATIONS**

**ELECTRICAL, ANALOG**

- 1. Relay Contacts
  - Load Supply Voltage = 120 VAC . . . . . 0.5 A
  - Load Supply Voltage = 24 VDC . . . . . 1.0 A
  - Load Supply Voltage = 60 VDC . . . . . 0.3 A
- 2. Power Supply
  - Supply Voltage Range
    - +5 V supply . . . . . 4.75 V - 5.25 V
  - Supply Current (all relays energized)
    - V = +5 V . . . . . 250 mA

**INDICATORS**

- 1. Card Accessed . . . . . Green LED
- 2. Relay Energized . . . . . Red LED
  - One LED per channel, numbered from top to bottom

**CONNECTORS**

- 1. 96-pin Euro connector (male) . . . . . AMP 650973-5
  - For card connector pin connections see Table 2, page 4.

**MECHANICAL**

- 1. Size (maximum overall dimensions as viewed from front)
  - Height . . . . . (11.9 cm) 4.68"
  - Width . . . . . (2.16 cm) 0.85"
  - Depth . . . . . (33.1 cm) 13.02"
  - Weight . . . . . (246 gm) 0.542 lb

**ENVIRONMENTAL**

- 1. Operating Temperature Range . . . . . (+32 °F - +104 °F) 0 °C - +40 °C
- 2. Storage Temperature Range . . . . . (-40 °F - +158 °F) -40 °C - +70 °C



PIN NO.	FUNCTION	PIN NO.	FUNCTION	PIN NO.	FUNCTION
1	Analog Ground	33	Channel 8 -	65	Channel 7 -
2	Analog Ground	34	No Connection	66	No Connection
3	Analog Ground	35	Channel 8 +	67	Channel 7 +
4	No Connection	36	No Connection	68	No Connection
5	Analog Ground	37	Analog Ground	69	Analog Ground
6	+30 V	38	+30 V	70	+30 V
7	Analog Ground	39	Channel 6 -	71	Channel 5 -
8	-15 V	40	-15 V	72	-15 V
9	Analog Ground	41	Channel 6 +	73	Channel 5 +
10	-15 V	42	-15 V	74	-15 V
11	Analog Ground	43	Analog Ground	75	Analog Ground
12	+15 V	44	+15 V	76	+15 V
13	Analog Ground	45	Channel 4 -	77	Channel 3 -
14	+15 V	46	+15 V	78	+15 V
15	Analog Ground	47	Channel 4 +	79	Channel 3 +
16	+5 V	48	+5 V	80	+5 V
17	Analog Ground	49	Analog Ground	81	Analog Ground
18	+5 V	50	+5 V	82	+5 V
19	Analog Ground	51	Channel 2 -	83	Channel 1 -
20	+5 V	52	+5 V	84	+5 V
21	Analog Ground	53	Channel 2 +	85	Channel 1 +
22	Digital Ground	54	Digital Ground	86	Digital Ground
23	Digital Ground	55	Digital Ground	87	Digital Ground
24	SDOB (P-1)	56	CS3 <sup>3</sup>	88	CS1 <sup>3</sup>
25	SDOA (P-1)	57	BS0 <sup>2</sup>	89	CS0 <sup>3</sup>
26	Spare	58	BS1 <sup>2</sup>	90	CS2 <sup>3</sup>
27	SSYNCB <sup>4</sup>	59	BS2 <sup>2</sup>	91	SCLK7B <sup>4</sup>
28	AD0 <sup>1</sup>	60	BS3 <sup>2</sup>	92	Spare
29	AD2 <sup>1</sup>	61	UAS	93	AD1 <sup>1</sup>
30	AD4 <sup>1</sup>	62	LAS	94	AD3 <sup>1</sup>
31	AD6 <sup>1</sup>	63	RD	95	AD5 <sup>1</sup>

Table 2 - 2008RY Card Connector Pin Connections

*Innovative Electronic Designs, Inc. • 9701 Taylorsville Road • Louisville, Kentucky 40299 • USA*  
*Phone: (502) 267-7436 • Fax: (502) 267-9070 • Internet: <http://www.iedaudio.com>*

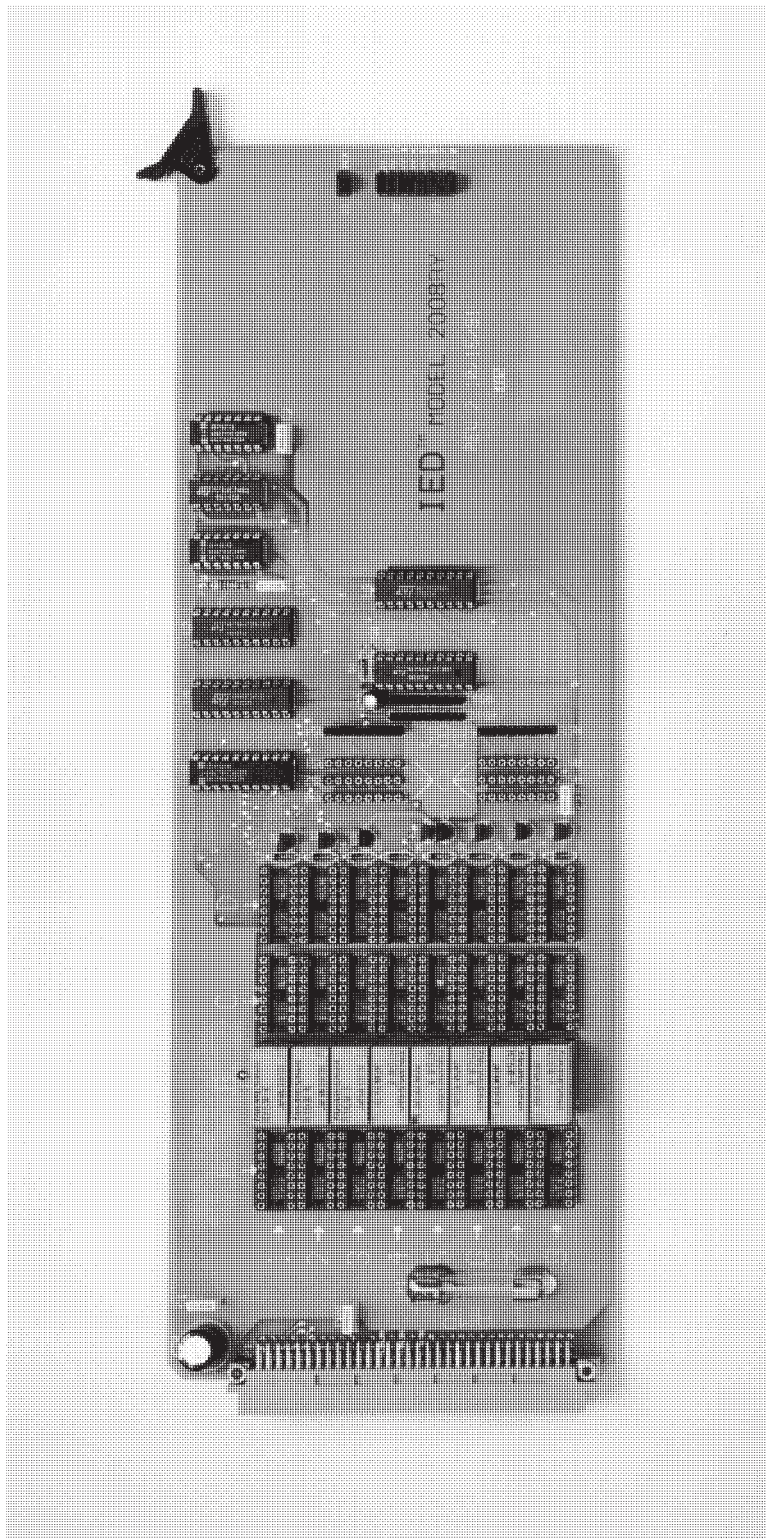

Figure 2 - 2008RY Multifunction Relay Card  
Relays shown in Option B position



This page intentionally left blank

*Innovative Electronic Designs, Inc. • 9701 Taylorsville Road • Louisville, Kentucky 40299 • USA  
Phone: (502) 267-7436 • Fax: (502) 267-9070 • Internet: <http://www.iedaudio.com>*